

NEW UNIVERSAL RULE OF MEASUREMENT CLASS M

SUPPLEMENTS TO THE MEASUREMENT RULE



VERSION 3.5.1

contact: info@universalrule.com

August 2019

SUPPLEMENTS to the MEASUREMENT RULE

USING THESE INTERPRETATIONS & CLARIFICATIONS

These Supplements to the New Universal Rule of Measurement for Class M are not part of the measurement rule itself, but rather clarify the rule, interpret parts of the rule that may be difficult to understand, and indicate the way in which the rule is to be interpreted or the methods by which it is to be applied. As such they have the same force and effect as if they were in fact part of the rule, but in some cases they will provide guidance which must be closely adhered to, but which does not set an absolute, exact limit, but which cannot be intentionally exceeded with a penalty, as would many parts of the rule itself.

CHANGE HISTORY

Changes in Version 3.5.1

- ◆ Supplement 17 is revised to deal with berths (including pipe berths) used in addition to the minimum number of built-in berths required by Rule Section 6.2.1.1.

Changes in Version 3.4.6

- ◆ Supplement 6 is eliminated, as it is no longer a requirement that rudders at the aft end of LWL be attached to the skeg in order for the skeg to be legal.
- ◆ Certain of the drawings were replaced by the same drawing in a different format to improve readability.
- ◆ Text in some Supplements was altered slightly to match the style of the rest of the document, but no changes were made to the content or specifics of the Supplements so altered.
- ◆ Supplement 11 is slightly revised to acknowledge the new minimum overall length minimum for Class M. There is no change to the meaning or application of the actual Supplement 11 material.

Changes in Version 3.4.1

- ◆ Supplement 7 is revised to increase the maximum beam allowed from 10.25 to 10.325 ft.
- ◆ Supplement 14 is added to answer questions about the legality of some specific hull shapes.
- ◆ Supplement 15 is added clarifying the purposes and limitations of the “demonstration” or “example” boats used in the measurement rule.
- ◆ Supplement 16 is added to clarify the possibility of a shallow hull with a taller keel.
- ◆ Supplement 17 is added to avoid any misunderstanding about the requirements for the interior of the boats.
- ◆ Supplements which are now obsolete have been marked as obsolete, but the text of those supplements has now been deleted to save space and avoid possible confusion.

Changes in Version 3.3.0

- ◆ Supplement 12 added to clarify the meaning and purpose, and hence proper interpretation, of the term “adjacent to” in Rule Section 8.1.2.

Changes in Version 3.2.1

- ◆ Version number advanced due to some issues in numbering. No changes to the actual Supplements. Numbers of figures in Supplement 9 were amended to the new numbering system which is based on Supplement number, so that Figure 1 in Supplement 9, which used to simply be called Figure 1, is now called Figure 9-1.

Changes in Version 3.2.0

- ◆ Added Supplement 10 discussing alternate construction methods.
- ◆ Added Supplement 11 regarding “reverse” or forward-sloping transoms.

Changes in Version 3.1.0

- ◆ Supplement 9 added to implement new method of determining what is a bulbed keel and what is not, following the change in that determination brought about by New Universal Rule of Measurement v. 11.3.0.
- ◆ Supplement 3 is now marked as obsolete due to the change in keel hollows rule and the resulting Supplement 9 which has now been added.

Changes in Version 3.0.0

- ◆ Addition of Supplement 8 on expected equipment to be included for the interior of the boat, including air conditioning, heating, desalination, etc.
- ◆ Supplement 2 Revised to include drawings of a more recent “demo” boat.
- ◆ Miscellaneous minor changes in wording in Supplements 1, 4, 5, and 7 to bring them into line with the most up-to-date designs and Rule version 11.

Table of Contents

CHANGE HISTORY	2
SUPPLEMENT 1	5
Hollows in the Stem of the Boat At or Below the LWL.....	5
SUPPLEMENT 2	6
Engine & Gear Box Combinations Evaluated for Rule Minimum PIPA Value.....	6
SUPPLEMENT 3	16
Clarification of Hollows Rule for Keels Where NACA 6-Digit Sections – OBSOLETE	16
SUPPLEMENT 4	17
Thin Flow-Directing Plates.....	17
SUPPLEMENT 5	18
Legality of Hollows in Waterlines, Diagonals and Buttocks.....	18
SUPPLEMENT 6	18
Spade Rudders Located in the Wake of Skegs -- OBSOLETE	18
SUPPLEMENT 7	19
Guidance with Respect to Breadth of Stern.....	19
SUPPLEMENT 8	19
Expectations With Respect to Interior Equipment -- OBSOLETE	19
SUPPLEMENT 9	19
Keels, Bulbs and Winglets -- OBSOLETE	19
SUPPLEMENT 10	20
Guidance on Wood and GRP Construction.....	20
SUPPLEMENT 11	21
Reverse or Forward-Sloping Transoms.....	21
SUPPLEMENT 12	26
Location of Engine with Respect to Owner's Cabin -- OBSOLETE	26
SUPPLEMENT 13	27
Keels, Bulbs and Winglets.....	27
SUPPLEMENT 14	31
Some General Questions about Hull Forms and Appendages.....	31
SUPPLEMENT 15	33
Some Notes Regarding the Example Boats Used in the Measurement Rule.....	33
SUPPLEMENT 16	33
Shallow Hulls with Higher Aspect Ratio Keels – Depth Penalty.....	33
SUPPLEMENT 17	37
Clarifications About Required Interior Arrangements.....	37
Expectations With Respect to Interior Equipment.....	37
Location of Engine with Respect to Owner's Cabin.....	38
Specific Design Guidance on Interior Arrangements & Weights.....	38
Guidance on Quantity and Nature of Berths.....	39

SUPPLEMENT 1***Hollows in the Stem of the Boat At or Below the LWL***

The Universal Rule of Measurement used to read:

“Any local concave jog or notch (curved or angular) at the plane of measurement of either end of the load waterline length, shall be bridged by a straight line and the L.W.L. shall be taken to the intersection of such lines with the established load waterline plane. The stem or stern profile lines where they cross the load waterline plane, may be **fair and easy curves**; but any concavity in the stem line shall be bridged by a straight line equal to one-third (1/3) of the greatest load waterline beam, placed equally above and below the waterline plane. The load waterline (L.W.L.) shall be measured to the intersection of this line with the established load waterline plane.” -- Universal Rule of Measurement, 1927

[emphasis added]

The clear implication of this statement is that the stem may be concave (although in the New Universal Rule for Class M, hollows in the profile are prohibited above the LWL in measurement trim). However, hollows close to the LWL were to be bridged.

The New Universal Rule for Class M also calls for bridging, but in the new rule, the bridge is a function of LWL, not beam.

In the section quoted above, it seems clear that “notches or jogs” in certain locations are uniformly to be bridged. However, “fair and easy curves” are permitted and are to be bridged only over the defined length. The fact that, however the meaning of this paragraph may have been understood, it clearly differentiates between a sharp “jog” and a “fair and easy curve” strongly suggests that the “notches and jogs” are discouraged, whereas “fair and easy curves” are acceptable unless they are located such that they influence the measurement of LWL, in which case they are not discouraged per se, but are bridged over a limited length.

Following on that, the New Universal Rule for Class M accepts a “fair and easy curve” but does not accept “notches or jogs” at the forward end of LWL and immediately aft thereof.

A “fair and easy curve” is not directly defined, but rather is taken to be a curve of a relatively large radius, such that it is clearly not a “notch” or a “jog”, but rather a curve. The use of the word “fair” is now completely avoided in order avoid arguments over what one designer or measurer might consider a fair curve and another might not. Any gradual curve, with a minimum radius clearly far larger than that of a “notch” or a “jog”, should ideally be accepted as satisfying this requirement, but that leaves a great deal of room for disagreement. As a guideline, **the New Universal Rule for Class M will accept a curve with a minimum radius of $0.95 * \text{Class Rating}$ or larger** as satisfying all requirements of this section, provided that none of the hollow extends above the LWL in measurement trim, *and provided that from the LWL to a point 3.00 feet (914 mm) below the LWL, the minimum radius as just defined in this paragraph may be located such that it contacts the stem anywhere in that region, without the stem having a smaller radius than $0.95 * \text{Class Rating}$ at that location.*

SUPPLEMENT 2***Engine & Gear Box Combinations Evaluated for Rule Minimum PIPA Value***

With the determination that the boats should have good interior arrangements, it follows clearly that they would also need power for operation of appliances, and engines and propellers for maneuvering and motoring, as lack of these abilities would render the interiors useless for any practical purpose.

For the engine and propeller, the problem was how to limit what could be used so as to avoid one boat being advantaged or disadvantaged by its engine selection or its propeller or propeller mounting. The Universal Rule has always been a rule which was concerned with the major rating parameters such as length, displacement and sail area, not with very small elements such as propeller strut width or hub length. In order to maintain that focus and avoid the kind of constant manipulating which can be necessary when including tiny elements such as those just mentioned directly in the rating calculation, it was decided to avoid direct inclusion of an allowance for propeller or mounting drag in the rating calculation. To do that, though, it was necessary to have some way to keep the drag of propellers and mountings, and the influence of the engine weight on stability and sea-keeping, reasonably under control.

For the engine, the requirement is that the engine/propeller combination drive the boat at an appropriate speed. Nine knots was chosen. To keep the engine out of, and away from, the owner's cabin, the specific requirement was put in that the engine could not be in or adjacent to the owners cabin, which encourages – without absolutely requiring – that the engine be more or less in the middle of the boat. That should keep the impact of the engine on motion in a seaway and on stability reasonably consistent from one boat to another.

A 3 blade propeller was specified to reduce noise and vibration. Propeller drag was taken into account by means of a minimum value of PIPA which each boat has to meet or exceed. Data was developed for several different engines and propeller mounts, and -- while the value of PIPA, which is very sensitive, varied somewhat for the different combinations -- the predicted performance of each, evaluated on two different hulls, indicates that effects on performance are only about 1/10 of one boat length per leg of the course in winds over 8 knots, and only about 1/4 boat length per leg in most lighter wind speeds. This assumes legs of 6 or 7 miles, such as one would have in a windward / leeward course of two windward and two running legs.

The following pages contain the trial data for two Class M hulls, each with a combination of engines and propeller shaft arrangements. The data contain the PIPA data for each combination that was used, and the V_{pp} results for those combinations, on the two hulls. The propeller shaft configurations were considerably different, as the accompanying illustrations on a more recent boat show. While this is not one of the boats used in the data, the configurations shown on this boat are typical of the two different configurations evaluated.

These all presume a 3-blade feathering propeller, which is a requirement in the rule.

Based on this work, it is considered clear that there are a number of engine and propeller arrangements which will all provide nearly identical performance for the boat when racing, so there is no need to include a calculation of PIPA or an engine allowance directly in the rating calculation. Specification of a minimum PIPA, along with the engine location and boat speed under power requirements, should be more than adequate.

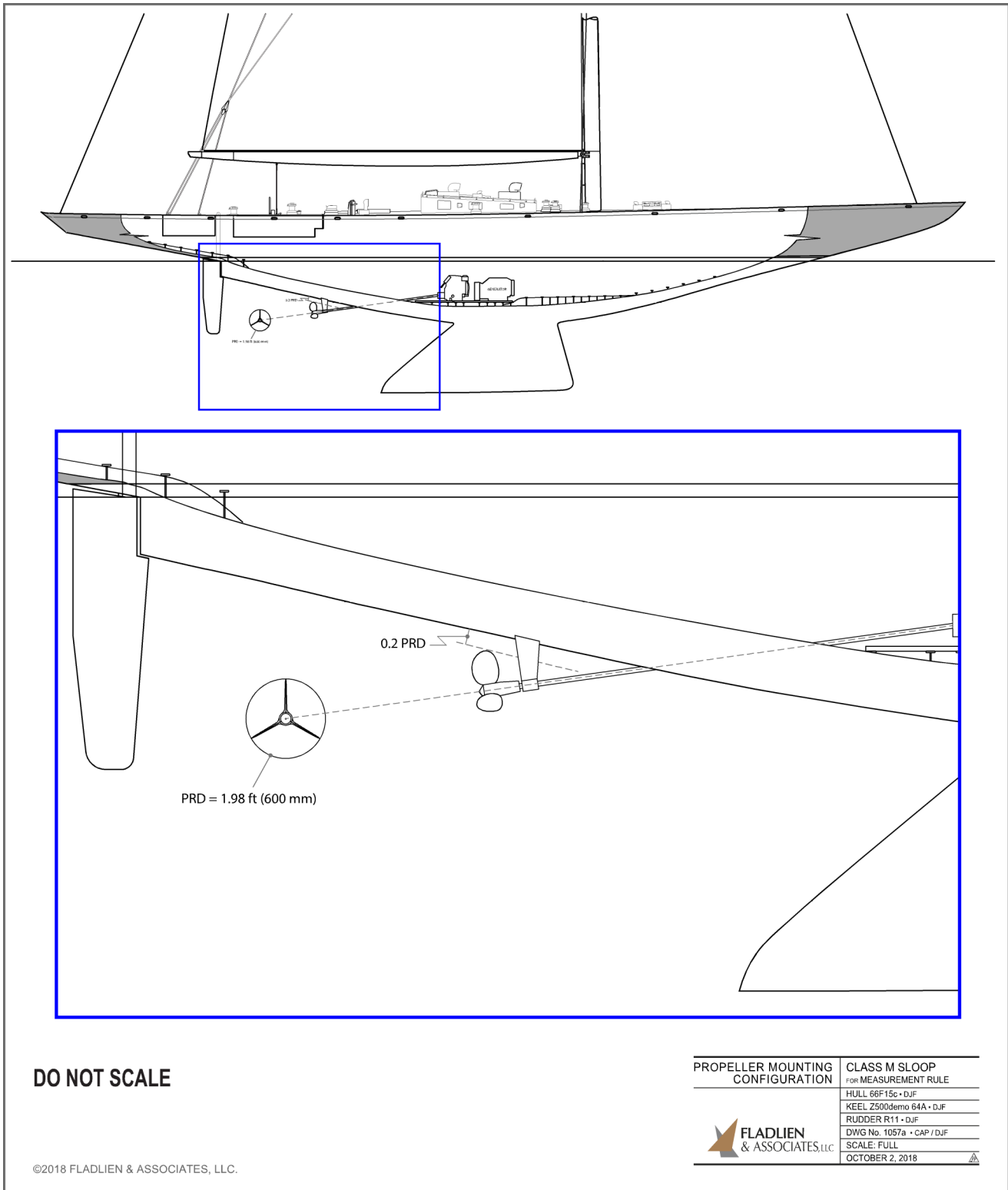

FIGURE 2-1a — PROPELLER MOUNTING CONFIGURATION

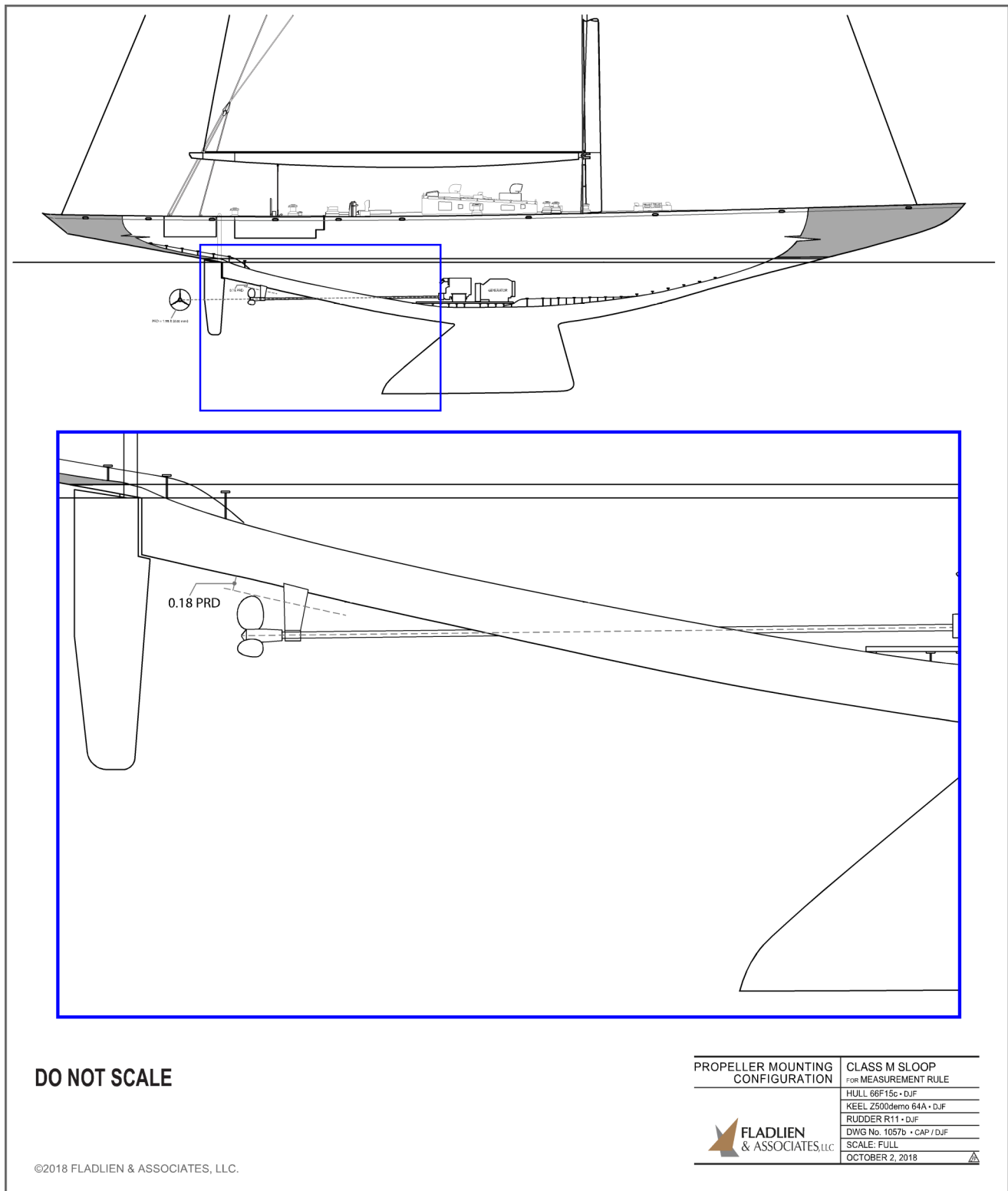

FIGURE 2-1b — PROPELLER MOUNTING CONFIGURATION

A1 - Hull "A" Per Dwg 354 Rev 15d**Yanmar 4J H4-TE with KM4A -2 Gear Box**

ITEM	SYMBOL	ENGLISH	METRIC
Hull : Prop Gap % of PRD		20%	20%
Propeller Shaft Angle	PSA	21.28	21.28
Propeller Shaft Length	ESL	3.837	1.170
Min Strut Thickness	ST1	0.082	0.025
Min Strut Width	ST2	0.394	0.120
Max Strut Width	ST3	0.481	0.147
Strut Hub Diameter	ST4	0.260	0.079
Strut Length	ST5	0.997	0.304
Propeller Shaft Diameter	PSD	0.112	0.034
Propeller Hub Length	PHL	0.694	0.212
Base Propeller Shaft Angle		7.000	7.000
Propeller Diameter	PRD	1.970	0.600
Blade Width	PBW	0.672	0.205
Propeller Hub Diameter	PHD	0.328	0.100
Propeller Hub Length	PHL	0.694	0.212
PIPA per WinDesign v4	0.0118372		

A2 - Hull "B" Dwg 403 -15d**Yanmar 4J H4-TE with KM4A -2 Gear Box**

ITEM	SYMBOL	ENGLISH	METRIC
Hull : Prop Gap % of PRD		20%	20%
Propeller Shaft Angle	PSA	22.75	22.75
Propeller Shaft Length	ESL	3.430	1.045
Min Strut Thickness	ST1	0.082	0.025
Min Strut Width	ST2	0.395	0.120
Max Strut Width	ST3	0.481	0.147
Strut Hub Diameter	ST4	0.260	0.079
Strut Length	ST5	0.935	0.285
Propeller Shaft Diameter	PSD	0.112	0.034
Propeller Hub Length	PHL	0.706	0.215
Base Propeller Shaft Angle		7.000	7.000
Propeller Diameter	PRD	1.970	0.600
Blade Width	PBW	0.672	0.205
Propeller Hub Diameter	PHD	0.327	0.100
Propeller Hub Length	PHL	0.706	0.215
PIPA per WinDesign v4	0.0120172		

B1 ▪ Hull "A" Per Dwg 354 Rev 13e**Volvo Penta D2-75 with MS25 Transmission**

ITEM	SYMBOL	ENGLISH	METRIC
Hull : Prop Gap % of PRD		20%	20%
Propeller Shaft Angle	PSA	21.62	21.62
Propeller Shaft Length	ESL	3.74	1.14
Min Strut Thickness	ST1	0.08	0.03
Min Strut Width	ST2	0.4	0.12
Max Strut Width	ST3	0.49	0.15
Strut Hub Diameter	ST4	0.26	0.08
Strut Length	ST5	0.99	0.3
Propeller Shaft Diameter	PSD	0.11	0.04
Propeller Hub Length	PHL	0.7	0.21
Base Propeller Shaft Angle		8.000	8.000
Propeller Diameter	PRD	1.97	0.6
Blade Width	PBW	0.67	0.21
Propeller Hub Diameter	PHD	0.33	0.1
Propeller Hub Length	PHL	0.7	0.21
PIPA per WinDesign v4	0.0119557		

B2 ▪ Hull "B" Dwg 403 -13e**Volvo Penta D2-75 with MS25 Transmission**

ITEM	SYMBOL	ENGLISH	METRIC
Hull : Prop Gap % of PRD		20%	20%
Propeller Shaft Angle	PSA	22.98	22.98
Propeller Shaft Length	ESL	3.44	1.05
Min Strut Thickness	ST1	0.08	0.03
Min Strut Width	ST2	0.4	0.12
Max Strut Width	ST3	0.49	0.15
Strut Hub Diameter	ST4	0.26	0.08
Strut Length	ST5	0.96	0.29
Propeller Shaft Diameter	PSD	0.11	0.04
Propeller Hub Length	PHL	0.68	0.21
Base Propeller Shaft Angle		8.000	8.000
Propeller Diameter	PRD	1.97	0.6
Blade Width	PBW	0.67	0.21
Propeller Hub Diameter	PHD	0.33	0.1
Propeller Hub Length	PHL	0.68	0.21
PIPA per WinDesign v4	0.0121598		

C1 - Hull "A" Per Dwg 354 Rev 13e**Lombardini LDW 2204 MT with TM 345 A Transmission**

ITEM	SYMBOL	ENGLISH	METRIC
Hull : Prop Gap % of PRD		20%	20%
Propeller Shaft Angle	PSA	21.62	21.62
Propeller Shaft Length	ESL	3.74	1.14
Min Strut Thickness	ST1	0.08	0.03
Min Strut Width	ST2	0.4	0.12
Max Strut Width	ST3	0.49	0.15
Strut Hub Diameter	ST4	0.26	0.08
Strut Length	ST5	0.99	0.3
Propeller Shaft Diameter	PSD	0.11	0.04
Propeller Hub Length	PHL	0.7	0.21
Base Propeller Shaft Angle		8.000	8.000
Propeller Diameter	PRD	1.97	0.6
Blade Width	PBW	0.67	0.21
Propeller Hub Diameter	PHD	0.33	0.1
Propeller Hub Length	PHL	0.7	0.21
PIPA per WinDesign v4	0.0119557		

C2 - Hull "B" Dwg 403 -13eL**Lombardini LDW 2204 MT with TM 345 A Transmission**

ITEM	SYMBOL	ENGLISH	METRIC
Hull : Prop Gap % of PRD		20%	20%
Propeller Shaft Angle	PSA	22.98	22.98
Propeller Shaft Length	ESL	3.44	1.05
Min Strut Thickness	ST1	0.08	0.03
Min Strut Width	ST2	0.4	0.12
Max Strut Width	ST3	0.49	0.15
Strut Hub Diameter	ST4	0.26	0.08
Strut Length	ST5	0.96	0.29
Propeller Shaft Diameter	PSD	0.11	0.04
Propeller Hub Length	PHL	0.68	0.21
Base Propeller Shaft Angle		8.000	8.000
Propeller Diameter	PRD	1.97	0.6
Blade Width	PBW	0.67	0.21
Propeller Hub Diameter	PHD	0.33	0.1
Propeller Hub Length	PHL	0.68	0.21
PIPA per WinDesign v4	0.0121598		

D1 - Hull "A" Per Dwg 354 Rev 13e**Lombardini LDW 2204 MT with TM 260 Transmission at ~4 Degree Angle**

ITEM	SYMBOL	ENGLISH	METRIC
Hull : Prop Gap % of PRD		22%	22%
Propeller Shaft Angle	PSA	19.42	19.42
Propeller Shaft Length	ESL	4.41	1.35
Min Strut Thickness	ST1	0.08	0.03
Min Strut Width	ST2	0.4	0.12
Max Strut Width	ST3	0.49	0.15
Strut Hub Diameter	ST4	0.26	0.08
Strut Length	ST5	1.06	0.32
Propeller Shaft Diameter	PSD	0.11	0.04
Propeller Hub Length	PHL	0.69	0.21
Base Propeller Shaft Angle		0	0
Propeller Diameter	PRD	1.97	0.6
Blade Width	PBW	0.67	0.21
Propeller Hub Diameter	PHD	0.33	0.1
Propeller Hub Length	PHL	0.69	0.21
PIPA per WinDesign v4		0.0117419	

D2 - Hull "B" Dwg 403 -13eL Angle**Lombardini LDW 2204 MT with TMC 260 Transmission at ~4 Degree Angle**

ITEM	SYMBOL	ENGLISH	METRIC
Hull : Prop Gap % of PRD		20%	20%
Propeller Shaft Angle	PSA	20.63	20.63
Propeller Shaft Length	ESL	3.87	1.18
Min Strut Thickness	ST1	0.08	0.03
Min Strut Width	ST2	0.4	0.12
Max Strut Width	ST3	0.49	0.15
Strut Hub Diameter	ST4	0.26	0.08
Strut Length	ST5	0.99	0.3
Propeller Shaft Diameter	PSD	0.11	0.04
Propeller Hub Length	PHL	0.69	0.21
Base Propeller Shaft Angle		0	0
Propeller Diameter	PRD	1.97	0.6
Blade Width	PBW	0.67	0.21
Propeller Hub Diameter	PHD	0.33	0.1
Propeller Hub Length	PHL	0.69	0.21
PIPA per WinDesign v4		0.0117	

E1 - Hull "A" Per Dwg 354 Rev 13e**Lombardini LDW 2204 MT with TMC 260 Transmission - Engine at ~4 Degree Angle**

ITEM	SYMBOL	ENGLISH	METRIC
Hull : Prop Gap % of PRD		24%	24%
Propeller Shaft Angle	PSA	19.42	19.42
Propeller Shaft Length	ESL	4.5	1.37
Min Strut Thickness	ST1	0.08	0.03
Min Strut Width	ST2	0.4	0.12
Max Strut Width	ST3	0.49	0.15
Strut Hub Diameter	ST4	0.26	0.08
Strut Length	ST5	1.1	0.34
Propeller Shaft Diameter	PSD	0.11	0.04
Propeller Hub Length	PHL	0.69	0.21
Base Propeller Shaft Angle		0	0
Propeller Diameter	PRD	1.97	0.6
Blade Width	PBW	0.67	0.21
Propeller Hub Diameter	PHD	0.33	0.1
Propeller Hub Length	PHL	0.69	0.21
PIPA per WinDesign v4		0.0118235	

E2 - Hull "B" Dwg 403 -13eL**Lombardini LDW 2204 MT with TMC 260 Transmission - Engine at ~4 Degree Angle**

ITEM	SYMBOL	ENGLISH	METRIC
Hull : Prop Gap % of PRD		28%	28%
Propeller Shaft Angle	PSA	20.5	20.5
Propeller Shaft Length	ESL	4.27	1.3
Min Strut Thickness	ST1	0.08	0.03
Min Strut Width	ST2	0.4	0.12
Max Strut Width	ST3	0.49	0.15
Strut Hub Diameter	ST4	0.26	0.08
Strut Length	ST5	1.14	0.35
Propeller Shaft Diameter	PSD	0.11	0.04
Propeller Hub Length	PHL	0.69	0.21
Base Propeller Shaft Angle		0	0
Propeller Diameter	PRD	1.97	0.6
Blade Width	PBW	0.67	0.21
Propeller Hub Diameter	PHD	0.33	0.1
Propeller Hub Length	PHL	0.69	0.21
PIPA per WinDesign v4		0.012038	

F1 ▪ Hull "A" Per Dwg 354 Rev 13e**Lombardini LDW 2204 MT with TMC 260 Transmission ▪ Engine at ~0.6 Degree Angle**

ITEM	SYMBOL	ENGLISH	METRIC
Hull : Prop Gap % of PRD		22%	22%
Propeller Shaft Angle	PSA	17.96	17.96
Propeller Shaft Length	ESL	5.02	1.53
Min Strut Thickness	ST1	0.08	0.03
Min Strut Width	ST2	0.4	0.12
Max Strut Width	ST3	0.49	0.15
Strut Hub Diameter	ST4	0.26	0.08
Strut Length	ST5	1.09	0.33
Propeller Shaft Diameter	PSD	0.11	0.04
Propeller Hub Length	PHL	0.69	0.21
Base Propeller Shaft Angle		0	0
Propeller Diameter	PRD	1.97	0.6
Blade Width	PBW	0.67	0.21
Propeller Hub Diameter	PHD	0.33	0.1
Propeller Hub Length	PHL	0.69	0.21
PIPA per WinDesign v4		0.0117133	

F2 ▪ Hull "B" Dwg 403 -13eL**Lombardini LDW 2204 MT TMC 260 Transmission ▪ Engine at ~1.0 Degree Angle**

ITEM	SYMBOL	ENGLISH	METRIC
Hull : Prop Gap % of PRD		29%	29%
Propeller Shaft Angle	PSA	17.99	17.99
Propeller Shaft Length	ESL	5.02	1.53
Min Strut Thickness	ST1	0.08	0.03
Min Strut Width	ST2	0.4	0.12
Max Strut Width	ST3	0.49	0.15
Strut Hub Diameter	ST4	0.26	0.08
Strut Length	ST5	1.22	0.37
Propeller Shaft Diameter	PSD	0.11	0.04
Propeller Hub Length	PHL	0.69	0.21
Base Propeller Shaft Angle		0	0
Propeller Diameter	PRD	1.97	0.6
Blade Width	PBW	0.67	0.21
Propeller Hub Diameter	PHD	0.33	0.1
Propeller Hub Length	PHL	0.69	0.21
PIPA per WinDesign v4		0.0117487	

HULL 'A' UPWIND PERFORMANCE with VARIOUS PROPELLER MOUNTINGS

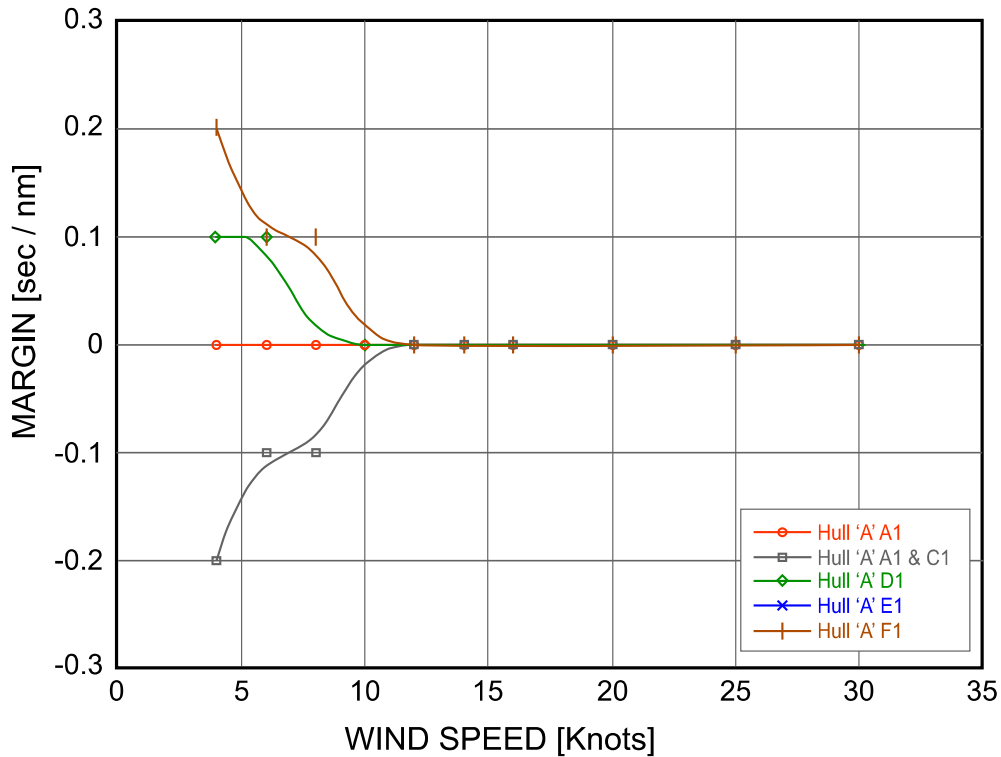

Above is the output of WinDesign v.4 for each of the propeller mountings evaluated, as used on Hull 'A', which is Hull 66F2, our original “demo” boat.

Please note that the margins on the left-hand column are in tenths of a second per mile, not seconds per mile.

Since 1.0 seconds per mile is very roughly 1 boat length per weather leg (actually less in very light wind as it takes a given boat longer to go a given distance), the difference between the “best” and the “worst” propeller mounting evaluated on this hull was 0.4 seconds / mile, or considerably less than ½ boat length per weather leg. For most practical purposes, the difference is negligible.

If one were to modify those poorer mountings to lower the PIPA to an value closer to the rule minimum 0.0117 value, the performance difference between the various mountings would be even less.

In short, on this hull the use of a minimum PIPA value, as opposed to incorporating that PIPA value into the rule, is definitely satisfactory, even where mounting differences are considerable.

HULL 'B' UPWIND PERFORMANCE with VARIOUS PROPELLER MOUNTINGS

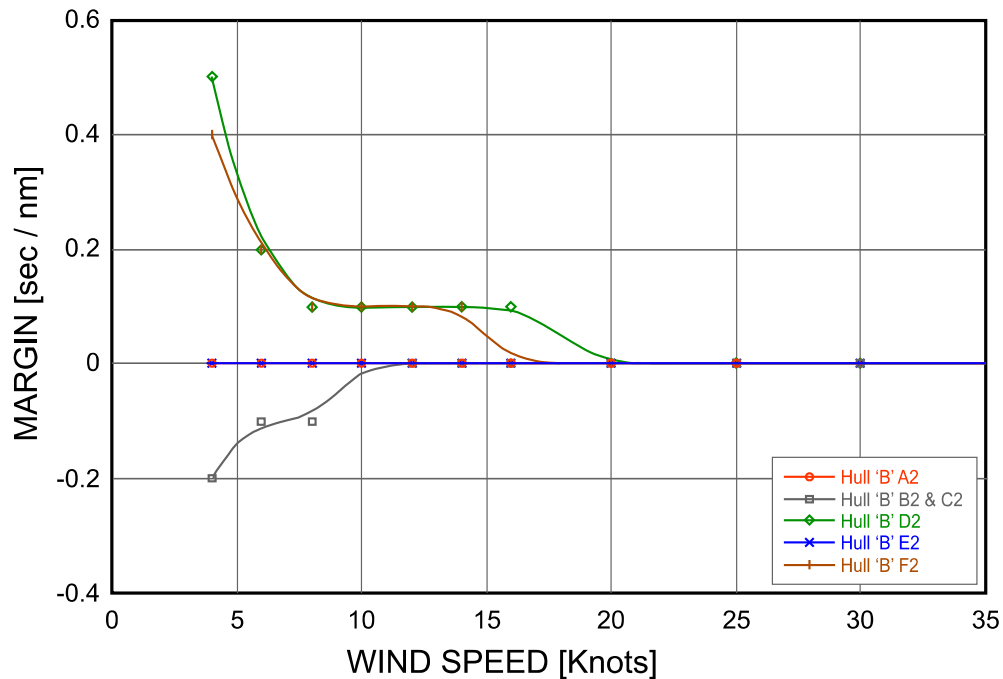

Above is the output of WinDesign v.4 for each of the propeller mountings evaluated, as used on Hull 'B', which is a much faster hull than Hull 'A' and is, therefore, not surprisingly a bit different from Hull 'A'. Again noting that the margins in the left side of the graph are tenths of second per mile, it is clear that Hull 'B' is twice as susceptible to performance changes due to propeller mounting as is Hull 'A'.

However, again allowing for the fact that the high value differences in performance occur only in the lightest of wind, the difference between the “best” and the “worst” propeller mountings on this boat are still only about ½ boat length over a windward leg. By working those mountings down to a lower PIPA, that difference could probably be reduced somewhat. So again it seems valid to use the minimum PIPA value rather than including PIPA in the boat's rating.

Most racing is in 8 to 25 knots of wind, at least for this kind of boat, and there the largest difference is about 0.2 sec / mile, or about two tenths of one boat length per weather leg.

SUPPLEMENT 3

Clarification of Hollows Rule for Keels Where NACA 6-Digit Sections – **OBSOLETE**

See Supplement 13

SUPPLEMENT 4***Thin Flow-Directing Plates***

The New Universal Rule of Measurement specifies that there can be only 1 set of winglets on a keel. This could raise a question about small, thin flow-directing plates, such as were used on the 12-Metre *Intrepid* in 1967. The very fact that they were used on a pre-1983 keel is itself a suggestion that it would be legal to use them today, but it is not clear if they would count as winglets.

For the purpose of this interpretation, a flow-directing plate will be considered to be a plate which appears on both sides of a keel or rudder, and which has an area *per side* of not more than 1 ft² (0.093 m²), and which has a maximum thickness not exceeding 0.5 in (12.5 mm), and is made of a material not heavier than aluminum.

Flow-directing plates may be placed anywhere on a keel or rudder. In case of doubt as to whether the location is in fact on a keel or rudder, a location below a point 5.900 ft (1.798 m) below the line of flotation in measurement trim shall be considered to be on a keel; a location such that all of the flow-directing plate is aft of the aft end of the LWL shall be considered to be on a rudder. For a location to be deemed below or aft of a certain point, all of the flow-directing plate must lie below or aft of that point.

A flow-directing plate which complies with the above restrictions may have any shape, but must be fixed in orientation (that is, it must not move or rotate, nor may it be allowed to move or rotate, *though the rudder to which it is attached may move in any manner in which a rudder is allowed to move*).

Flow-directing plates are not permitted on hulls, or on appendages other than rudders, trim tabs or keels, as defined in the New Universal Rule of Measurement.

NOTE: a flow-directing plate is not a turbulence stimulator for purpose of this interpretation.

SUPPLEMENT 5***Legality of Hollows in Waterlines, Diagonals and Buttocks***

There are several sections of the New Universal Rule of Measurement which deal directly with hollows other than those in the above-water profile and above-water deck planform of the hull, and other than those in the keel. In other words, these sections deal with hollows in the surface of the hull but which do not create hollows in the edges of the surface such as the sheerline planform or the above-water stem or counter profile of the boat.

A question could arise about these hollows since some of them seem to appear in boats built prior to 1960 and others do not, and in many cases it is not clear, or at least not readily clear, whether they did in fact occur historically in the time period with which we are concerned in Rule Appendix 1, which considers how to determine the legality of proposed hull shapes.

The guiding principle here is whether the traditional overall appearance and sailing characteristics of the boat is significantly compromised by the proposed shape. But as that requires – in any given case – some kind of formal determination by the Class M Rules Committee, the following guidance is offered with the view that it is meant to be relied upon by the designer in determining the legality of shapes which include hollows in waterlines, diagonals or buttocks, in cases where they do not create hollows in the above-water profile or sheerline planform of the boat, and where they do not extend into the keel.

As a general statement, hollows are permitted in waterlines, in diagonals and in buttocks, even if those hollows are severe or sharp, and regardless of their location. However it should be noted that they are often subject to bridging, as specified in the Rule, and that the forward end of QBL may not under any conditions be taken as further aft than $0.117 \times \text{LWL}$ aft of the forward end of LWL.

In terms of historical precedent, the famous R-boat *Lady Van*, designed by Charles E. Nicholson, demonstrates deep hollows in the forward diagonals, for example, and – while they are not nearly as severe as more “modern” hollows – there do seem to be hollows in the after diagonals of other historical boats as well. Thus, while this Supplement indicates that even severe hollows are to be permitted if they meet the requirements of the above paragraphs, this Supplement is not in most ways grossly out of keeping with the tradition of the Universal Rule, as later shapes developed under the International Rule indicate. Those later shapes, while not covered by the historical sections of Appendix 1 of the New Universal Rule, do strongly suggest that it was only because the concepts had not yet been envisioned that they were not used in the relevant historical period.

Finally, as seen in the later International Rule boat development, such as the 12-Metre *Courageous* in its original form, even sharp notches in diagonals did not alter the inherent appearance or performance characteristics of the boat.

SUPPLEMENT 6***Spade Rudders Located in the Wake of Skegs -- OBSOLETE***

SUPPLEMENT 7***Guidance with Respect to Breadth of Stern***

The guiding principle for the New Universal Rule of Measurement is that the contemporary boat should maintain the same basic appearance and performance characteristics as the original M Class boats, but with modernized design concepts, construction methods, and equipment. It is further stated by way of clarification in Appendix 1 of the Rule that the profile of the boat above water must adhere fairly closely to the appearance of the above-water profile of the earlier M Class or other Universal Rule or International Rule boats built prior to 1960 (though the stem and counter angles are to be regulated by the minimums set in the Rule itself), but that the planform of the boat's sheerline could have considerably greater flexibility and still meet the requirements of the Rule.

The possibility has arisen that this freedom of shape in the planform of the hull could be abused, intentionally, or even unintentionally out of differing interpretations of the limits on form. Therefore the following is offered as guidance on maximum breadth of the stern of the boat.

The maximum beam of the boat, taken at any height in the transverse plane, at a horizontal distance 12% of the Class Rating (46.0 ft) aft of the aft end of LWL, shall be not greater than 10.325 ft (3.147 m).

The Class Rating is used as the basis for determining this location rather than B or LWL. At least with boats which have a vertical profile at the aft end of LWL, this methodology then avoids the problem where the boat is floated higher due to change in ballasting, and the LWL becomes shorter and B becomes narrower as a result of the higher flotation. The result would then be that the plane for measuring the breadth in question would move forward and the breadth with which the boat was built becomes too large, without anything other than the flotation having changed. As the Class Rating is not a function of flotation, this problem is for most boats avoided.

If it appears that for some reason having to do with the shape of the profile of the boat at or near the aft end of LWL, the particular boat in question is not treated fairly, the matter should be referred to the Rules Committee immediately.

This requirement is placed in the Supplement, not in the Rule itself, as it is meant to be a close guidance, which is to be enforced in the case of any significant violation. There is no penalty because this is not a restriction which is intended to be subject to violation as part of a legitimate development of a faster boat, in which case a penalty would be taken. Therefore, a tiny and inadvertent violation of this limit is to be ignored, as its impact on performance and appearance is insignificant, but any significant violation, even if very small, must be corrected.

SUPPLEMENT 8***Expectations With Respect to Interior Equipment -- OBSOLETE***

See Supplement 17

SUPPLEMENT 9***Keels, Bulbs and Winglets -- OBSOLETE***

See Supplement 13

SUPPLEMENT 10***Guidance on Wood and GRP Construction***

Some time back, a designer inquired about GRP (glass reinforced plastic) construction, aka “fiberglass”. That of course leads also to questions about wood construction as well. The position of the present Rules committee on alternate forms of construction, specifically wood and GRP is:

The basic construction for the New Universal Rule Class M is the aluminum construction scantlings specified in the current version of the Rule. It is the expectation of the Rules committee that those scantlings will set the standard for weight and for weight distribution. However, it is not the purpose of the scantlings to limit construction to aluminum, and the Rules committee is in principle willing to consider wood or GRP construction, provided that:

- ◆ the designer of the boat submits detailed and thorough evidence to show that there is no advantage in weight or weight distribution to the construction that he/she proposes;
- ◆ that there is no use of any material having a tensile modulus greater than that of common boat-building woods (in the case of wood construction) or greater than that of e-glass in the case of GRP.
- ◆ This effectively prohibits exotic materials in the construction of the hull, deck, cockpits or interiors, except as permitted in the New Universal Rule of Measurement, for Class M, General Provisions.

It is the intention of the Rules committee to work out a set of scantlings for wood construction, following the basic concept of strip planking with multiple layers of veneer on top of the strip planking. There is no specific schedule for this work, nor is there any estimated completion date. Input from interested parties is welcome, as it would be about GRP as well, though there is no plan at the moment to create a set of scantlings for GRP.

This Supplement should not be taken as a rejection of any particular method of wood or GRP construction which complies with the requirements of the indented sections above. Proposals for boats built by other methods which comply with the indented sections above should be submitted to the Rules committee for consideration.

SUPPLEMENT 11
Reverse or Forward-Sloping Transoms

While the New Universal Rule definitely intends to maintain the long overhanging ends associated with this kind of boat, it is not the intention of this rule to tell owners what kind of transom they must or must not have on their boats. If the following analysis and calculations seem over-blown, please keep in mind that they are in fact practically necessitated by the intensity of feeling which some people have about transom shapes.

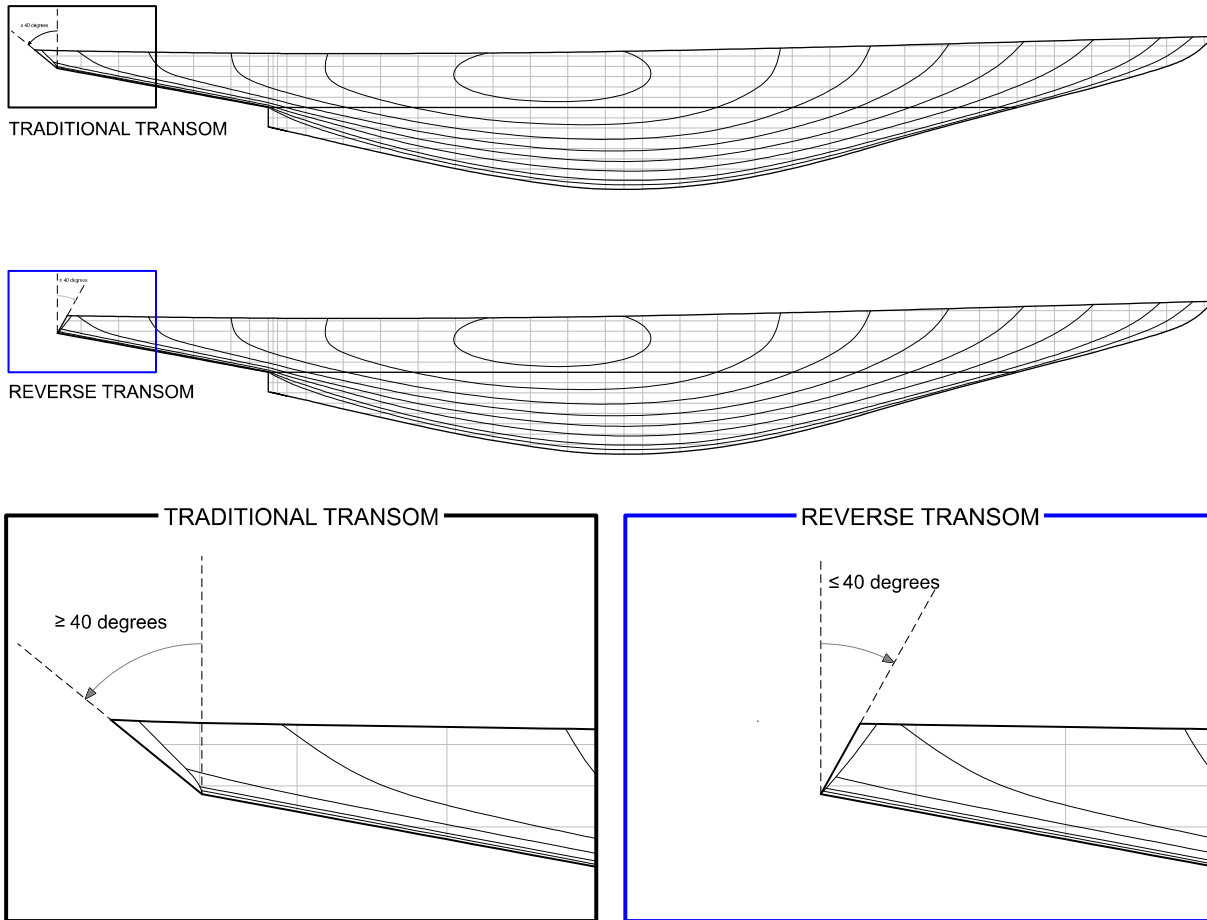

FIGURE 11-1 — CLASS M TRANSOMS per RULE 1.3.6.2

Figure 11-1 illustrates what we mean by a traditional transom and a reverse transom. Properly done, both can be very attractive. Section 1.3.6.2 of the Rule specifies limits on the slope of either form of transom to keep the shapes reasonable. The same section also specifies that the transom is always part of the hull, not part of the deck, so that the construction employed must match the requirements for the hull, not for the lighter deck. Figure 11-1 also illustrates the slope requirements of section 1.3.6.2.

Rule Section 1.3.6.2 includes the following statement: “Where a reverse transom is used, special transom construction regulations apply so that no significant advantage in weight or weight distribution is achieved.”

The purpose of this requirement is to ensure that each boat can have the type of transom that boat's owner desires, and at the same time will incur no – or at most very little – cost in performance because of that owner's

selection. This is especially important with the reverse transom, as it has a basic inherent advantage if its base, or bottom, is at, or forward of, the base or bottom of the traditional transom, and if the construction is identical.

The reason for this advantage is that the weight of the traditional transom is aft of the weight of the reverse transom in those cases, and therefore is in a poorer location regarding motion in a seaway. Further, some of the weight of the hull and deck surfaces immediately forward of the transom can actually be eliminated by use of the reverse transom, thus increasing stability and driving power.

The weight eliminated by the reverse transom itself is probably less than many people think, as there still has to be a transom, and in fact the reverse transom itself will probably weigh more than the traditional transom, since – being further forward – it will also be wider and deeper than the corresponding traditional transom. Hence most of the weight saved will probably be the weight of the topside materials and deck materials which are eliminated. These can be substantial though, especially in the case where, as in this class, there is both a structural deck and a wood covering on the deck. There may be some additional saving if the reverse transom is significantly more vertical than the conventional transom, such that it uses less material to manufacture. This will probably be a very small saving, however.

Several transom configurations were evaluated for the purpose of defining a way of quantifying the additional weight, if any, that should be put into a reverse transom to prevent any advantage due to weight saving or weight distribution. Figure 11-2 shows these configurations. The traditional transom configuration, and reverse transoms 2 and 3 are all for the same hull. We had drawn an alteration of this hull which made the stern narrower on deck, and its transom, transom 4, is included to check on the effect of narrower sterns, but also to ensure that a narrower stern does not lose its weight advantage in these weight

compensations. The weight compensations are intended only to nullify benefits of using a reverse transom, not to nullify the benefits of making the stern narrower. The compensations do, however, nullify the advantage of shortening the stern overhang by means of a reverse transom, as one of the benefits of the reverse transom is that the overhang can be shortened with no loss in bearing surface of the boat.

While it is always possible that the data presented here will not bracket every proposed design, the overall lengths indicate that the boat with the traditional transom is in fact quite long. At the other end of the spectrum, reverse transom 3 is actually below the Rule version 12 minimum LOA specified in Rule Section 1.3.6.1, as its inclusion in this supplement preceded the current length minimum limit. Also, the transom widths of the traditional transom and transom 2 in the data are for a boat of nearly the maximum stern width under Supplement 7, so it is assumed that most boats will fall within, or very close to, the transom designs evaluated here, once the breadth of the stern is included in the evaluation, which is accomplished here by inclusion of reverse transom 4.

For purpose of this evaluation, “transom area” is taken as a flat plate, the external shape of which is that of the transom frame. “Deck area” is taken to be the area of the deck in the specified regions, again assuming the deck is flat. In reality the transom and the deck will probably, though not necessarily, be curved, but the curvature if any would presumably be nearly identical for any transom configuration proposed for that particular boat, so that curvature, which is arbitrary, almost completely ceases to be a significant factor for that particular boat.

“Hull Surface Area” was determined by taking the transom frame, and the reference station forward of it, as indicated in Figure 11-2, and doing a standard CAD “loft” or “extrude”, then taking the centroid as given by the software. This too will not be *absolutely* precise, as there is some *very slight* curvature to the hull surface in that area, but this curvature is again more-or-less constant *for a given hull*, and is insignificant in magnitude.



FIGURE 11-2 — TRANSOMS EVALUATED

TABLE 1 – Uncompensated Configuration	Traditional Transom	Reverse Transom 2	Reverse Transom 3	Reverse Transom 4
Hull LOA for Respective Configuration (ft)	86.26	85.45	84.38	85.45
Transom Planar Surface Area (ft ²)	9.68	10.09	12.34	9.17
Transom Material Weight (lbs/ft ²)	4.38	4.38	4.38	4.38
Transom Planar Weight (lbs)	42.35	44.14	53.99	40.14
Transom Arm Aft Nominal LCF (ft)	40.74	39.96	38.81	39.98
Transom Moment Aft Nominal LCF (ft-lbs)	1726	1764	2095	1605
Deck Planar Area (ft ²)	23.53	11.65	2.91	10.68
Deck Material Weight (lbs/ft ²)	5.33	5.33	5.33	5.33
Deck Planar Weight (lbs)	125.41	62.09	15.5	56.94
Deck Arm Aft Nominal LCF (ft)	39.81	38.92	38.42	38.99
Deck Moment Aft Nominal LCF (ft-lbs)	4993	2417	595	2220
Hull Surface Area Aft Reference Station (ft ²)	17.59	19.94	10.03	18.37
Hull Surface Material Weight (lbs/ft ²)	4.38	4.38	4.38	4.38
Hull Surface Weight Aft Reference Station (lbs)	76.96	87.24	43.88	80.37
Hull Surface Arm Aft Nominal LCF (ft)	39.2	39.32	38.81	39.31
Hull Surface Moment Aft Nominal LCF (ft-lbs)	3016	3430	1703	3159
Area of Deck Segment 2 ft Forward of Reference (ft ²)	15.76	15.76	15.76	14.5
Segment Material Weight (lbs/ft ²)	5.33	5.33	5.33	5.33
Segment Deck Planar Weight (lbs)	84	84	84	77.29
Segment Arm Aft Nominal LCF (ft)	37.1	37.1	37.1	37.17
Segment Moment Aft Nominal LCF (ft-lbs)	3117	3117	3117	2872
Compensating Weights Material Weight (lbs/ft ²)	0	0	0	0
Compensating Weights Total Weight (lbs)	0	0	0	0
Compensating Weights Arm Aft Nominal LCF (ft)	0	0	0	0
Compensating Weights Moment Aft Nominal LCF (ft-lbs)	0	0	0	0
Transom Width (ft)	6.70	7.20	7.58	6.29
Required Structure Weight (lbs)	329	329	337	307
Required Structure Moment Aft nominal LCF (ft-lbs)	12852	12852	12852	12015
Actual Weights (lbs)	329	277	197	255
Actual Moments (ft-lbs)	12852	10728	7510	9856

Working with the basic parameters available in Table 1, it was quickly found that compensation for the weight saving and location differences using differing material thicknesses in the construction of that part of the boat was impractical. The fact that aluminum, or even fiberglass if it were to be approved, comes in specific thicknesses effectively prevents arriving at an exact compensation. In fact, while it is possible to get very close with reverse transom 2, reverse transoms 3 and 4 proved much more difficult.

At length, it was determined that it would be necessary to add separate compensating weights, and leave the structure weights as specified in the rule, except for the transom itself, which can readily be increased to 1/2" aluminum. It is probably preferable not to increase any other structure weights in any case, since it is much easier to adjust the compensating weights if required due to modification of the boat, where the weights are separate items, not an inherent part of the structure.

Table 2 shows how these efforts turned out with separate compensating weights. In each case, the final weight is very close to the required weight (which is the traditional transom weights adjusted for the breadth of the transom, as discussed above, which is why reverse transom 4 has a lower requirement).

TABLE 2 – Compensated Configuration	Traditional Transom	Reverse Transom 2	Reverse Transom 3	Reverse Transom 4
Hull LOA for Respective Configuration (ft)	86.26	85.45	84.38	85.45
Transom Planar Surface Area (ft ²)	9.68	10.09	12.34	9.17
Transom Material Weight (lbs/ft ²)	4.38	7.00	7.00	7.00
Transom Planar Weight (lbs)	42.35	70.63	86.38	64.22
Transom Arm Aft Nominal LCF (ft)	40.74	39.96	38.81	39.98
Transom Moment Aft Nominal LCF (ft-lbs)	1726	2823	3352	2567
Deck Planar Area (ft ²)	23.53	11.65	2.91	10.68
Deck Material Weight (lbs/ft ²)	5.33	5.33	5.33	5.33
Deck Planar Weight (lbs)	125.41	62.09	15.5	56.94
Deck Arm Aft Nominal LCF (ft)	39.81	38.92	38.42	38.99
Deck Moment Aft Nominal LCF (ft-lbs)	4993	2417	595	2220
Hull Surface Area Aft Reference Station (ft ²)	17.59	19.94	10.03	18.37
Hull Surface Material Weight (lbs/ft ²)	4.38	4.38	4.38	4.38
Hull Surface Weight Aft Reference Station (lbs)	76.96	87.24	43.93	80.37
Hull Surface Arm Aft Nominal LCF (ft)	39.2	39.32	38.81	39.31
Hull Surface Moment Aft Nominal LCF (ft-lbs)	3016	3430	1705	3159
Area of Deck Segment 2 ft Forward of Reference (ft ²)	15.76	15.76	15.76	14.5
Segment Material Weight (lbs/ft ²)	5.33	5.33	5.33	5.33
Segment Deck Planar Weight (lbs)	84	84	84	77.29
Segment Arm Aft Nominal LCF (ft)	37.1	37.1	37.1	37.17
Segment Moment Aft Nominal LCF (ft-lbs)	3117	3117	3117	2872
Compensating Weights Material Weight (lbs/ft ²)	0	7.00	14.00	7.00
Compensating Weights Total Weight (lbs)	0	25	107	30
Compensating Weights Arm Aft Nominal LCF (ft)	0	39.92	38.2	39.92
Compensating Weights Moment Aft Nominal LCF (ft-lbs)	0	998	4087	1198
Transom Width (ft)	6.7	7.2	7.58	6.29
Required Structure Weight (lbs)	329	329	337	307
Required Structure Moment Aft nominal LCF (ft-lbs)	12852	12852	12852	12015
Actual Structure Weights (lbs)	329	329	337	309
Actual Moments (ft-lbs)	12852	12784	12857	12017

As seen in Table 2, there is a very close correspondence of the weights and the moments to the required totals. Careful attention to be sure that there is no large difference between the location of the compensating weights and that of the weights removed by the reverse transom, insures that the effect on righting moment and on pitching moment in a seaway should be very small. For the kind of racing envisioned for this class, which is serious but fun racing, not the very serious form as has been seen in grand prix or America's Cup racing, this methodology should be adequate, and is not all that difficult for the designer(s) to implement.

There remain the centerline structure and framing to take into consideration. Figure 11-3 shows the areas of centerline structure impacted by each reverse transom.

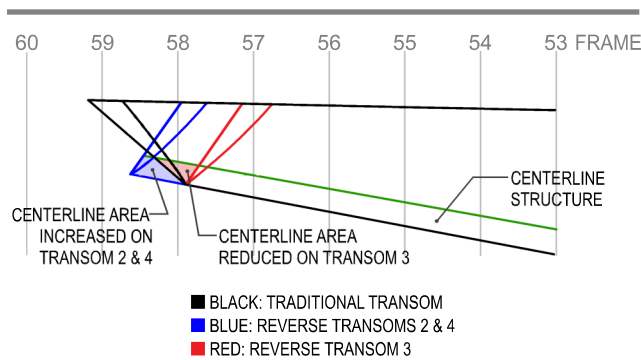

FIGURE 11-3 — INTERNAL STRUCTURES

In the case of reverse transom 3, the red shaded area indicates the additional weight saving due to the reverse transom. In the case of reverse transoms 2 and 4, there is actually a weight loss, that is, weight is higher for the reverse transoms than for the traditional transom, so that this area, the blue shaded area, the corresponding weight has to be *subtracted* from the weight compensation.

The weights concerned are:

- Transom 3: -3.16 lbs (actual weight increase)
- Transom 4: 2.13 lbs (actually saved)

In these cases, the compensating weights given in Table 2 will have to be altered slightly to allow for the changes in centerline structure. In the case of Transom 3, the compensating weight needs to be increased by 2.13 lbs; in Transom 2 and Transom 4, the compensating weight actually needs to be *reduced*, as the centerline structure weight is actually increased by the use of that particular reverse transom.

Finally, it will be necessary to deal with any changes in the weight of the related frames. Figure 11-4 illustrates the principle involved. In this illustration, the shaded area represents the frame web removed by the fact that it is cut off by the reverse Transom 2. In practice there would be larger changes relating to fitting in the transom internal structure, but there is internal transom structure to any transom, so the weight we are concerned with is the weight removed from the web and flange.

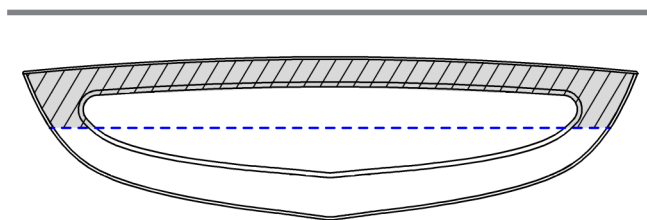

FIGURE 11-4 — FRAME CUT BY REVERSE TRANSOM

For Transom 2, that amount is 1.35 lbs for the web, and 2.83 lbs for the flange, making a total addition to the compensation weight of 4.18 lbs. For transom 3, the entire frame is eliminated, as it sits aft of the stern ending of the boat, so its addition to the compensation weights would be 25.06 lbs to compensate for the frame and flange.

The process involved then requires that the boat which is to have a reverse transom, also have a reference transom of the traditional type, from which the compensation weights are calculated. Lines plans with longer counters than will be needed can be drawn, and trimmed to length once the designer has made a determination of what the counter length should be.

If the designer begins with a counter with a transom of the traditional type, he / she then will have a transom 1, which is then used as the reference transom in that designer's calculations, just as the traditional transom was used as the reference transom for the calculations in this example. The designer can then complete a column of the spreadsheet in Table 2 to calculate the compensation weights for deck and deck sheathing, transom area, and hull shell surface area as described and defined above. In a similar manner, that designer can use a frame 58 drawing and a centerline drawing to arrive at the additions or deductions appropriate for that transom in the compensation weights. The "artificial" traditional transom to be used for this purpose should be drawn at the longest counter length which may be used, up to the sheerline at the minimal transom centerline angle of 40 degrees to vertical. If someone wants a traditional transom of greater angle, then they will have to absorb the very tiny amount of weight added – to the stern of the boat, not the foredeck – by that angle.

Compliance with this Supplement for a proposed boat, will be considered to be compliance with the "Special Transom Construction Regulations" referred to in Rule Section 1.3.6.2.

Where any designer or owner feels these simplifications do not treat their design fairly, they can submit their situation to the Rules Committee after the boat is built. If the Rules Committee determines that greater or lesser compensation weights are appropriate, the actual compensation weights can be adjusted to those approved by the Rules Committee at the time the boat is measured.

SUPPLEMENT 12

Location of Engine with Respect to Owner's Cabin -- OBSOLETE

See Supplement 17

SUPPLEMENT 13***Keels, Bulbs and Winglets***

Effective with New Universal Rule of Measurement v. 11.3.0, the prohibition against hollows in the transverse sections of keels was eliminated.

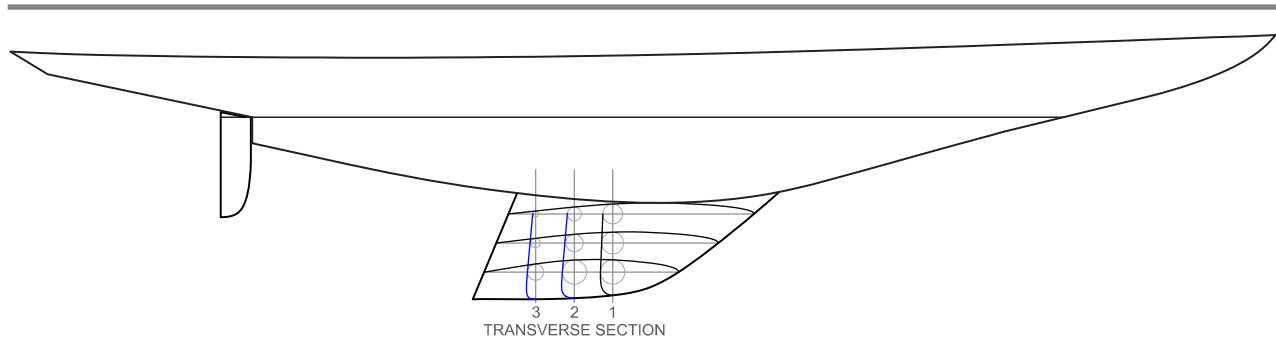

FIGURE 13-1a — LEGAL KEEL CONFIGURATION #1

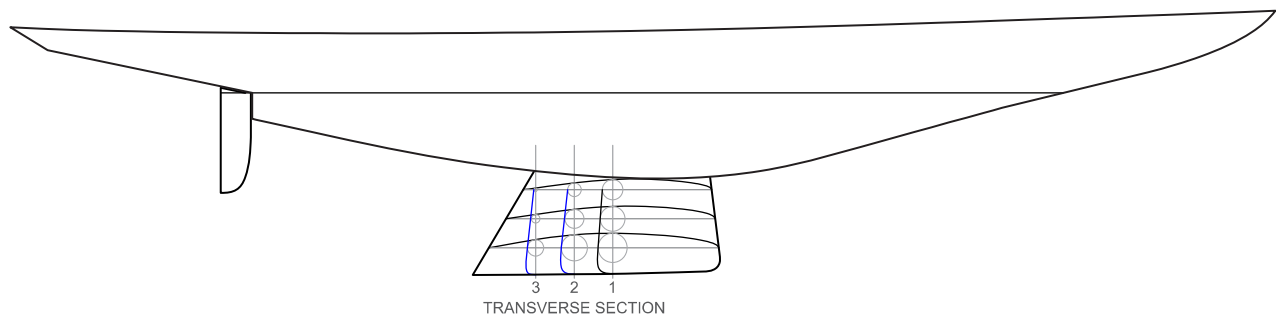

FIGURE 13-1b — LEGAL KEEL CONFIGURATION #2

However, the prohibition against bulbs on keels, and more generally, against fin-and-bulb keels, remains. The fin-and-bulb prohibition is already covered in Rule Section 3.2.2, in the text and in its accompanying Figure 6. What changed was the method of determining whether some shape constitutes a bulb in a keel which complies in profile with Figure 6. Prior to Rule version 11.3.0, the method was to define a bulb as a keel with a transverse section containing a hollow in the vertical plane. Effective with Rule version 11.3.0, the method of determining what constitutes a bulb was changed to a method using a radius of curvature in that plane. With the increase in maximum draft without penalty in Rule version 11.7.0, that same radius methodology was retained, but the required radius has had to be altered to correspond to the greater span of the keel itself. This Supplement covers that and some related changes.

The guiding principle now will be that a bulb is defined as a vertical concavity in the transverse plane of the keel, with radius less than $0.32 * \text{the Class Rating}$, when such concavity is located below the -6.50 ft (-1.981 m) waterline. This is arrived at as follows:

The present Rule wording specifically identifies that bulbs are prohibited, but that tip chord sections greatly thicker (in thickness percentage and/or dimension) than the root chord are permitted, provided that the increase is gradual, not sudden. Even with this wording a certain amount of ambiguity is unavoidable, and legitimate questions could arise. In an effort to provide a basis for resolution of those questions, and also to provide a workable and uniform guidance to designers without asking them to divulge confidential design concepts in order

to obtain a ruling, the following history and guidelines are offered. Note that these, being in a supplement, are to be considered normative, as if part of the Rule, but not considered absolute, such that even a very tiny deviation would be prohibited or penalized as it would be under the Rule itself. As is the case with supplements, a very tiny and apparently unintentional violation would be ignored, while any significant, substantial, or apparently deliberate attempt to circumvent the intent of the supplement would be definitely disallowed.

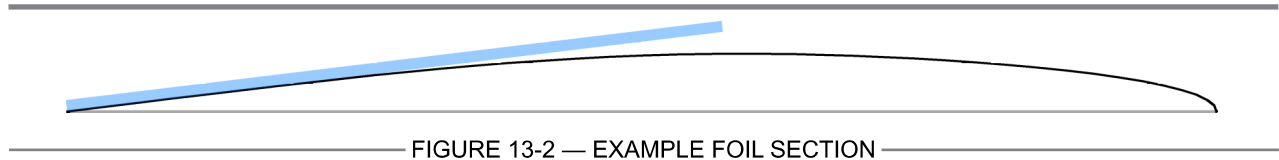

FIGURE 13-2 — EXAMPLE FOIL SECTION

Figure 13-1a and Figure 13-1b show two examples of keels with legal planforms where transverse hollows could arise, and would always have been shapes the Rule wished to permit, though in fact the wording prior to v. 11.3.0 would have prohibited them because of the resulting transverse section hollows. If the reader looks closely at transverse section 3 of each keel, he/she will see the hollow at the middle foil section, as the circle indicating the breadth of the foil at that transverse section is narrower than the straight line (blue) connecting the upper and lower foil sections. This is not due to a hollow in the trailing portion of the foil section itself. Figure 13-2 shows an enlarged version of the foil section. As the blue line indicates, there is no hollow in this foil, which was drawn deliberately to illustrate this point.

The question is then, what constitutes a bulb for purposes of this supplement, and how is some proposed shape determined definitively to be, or not be, a bulb.

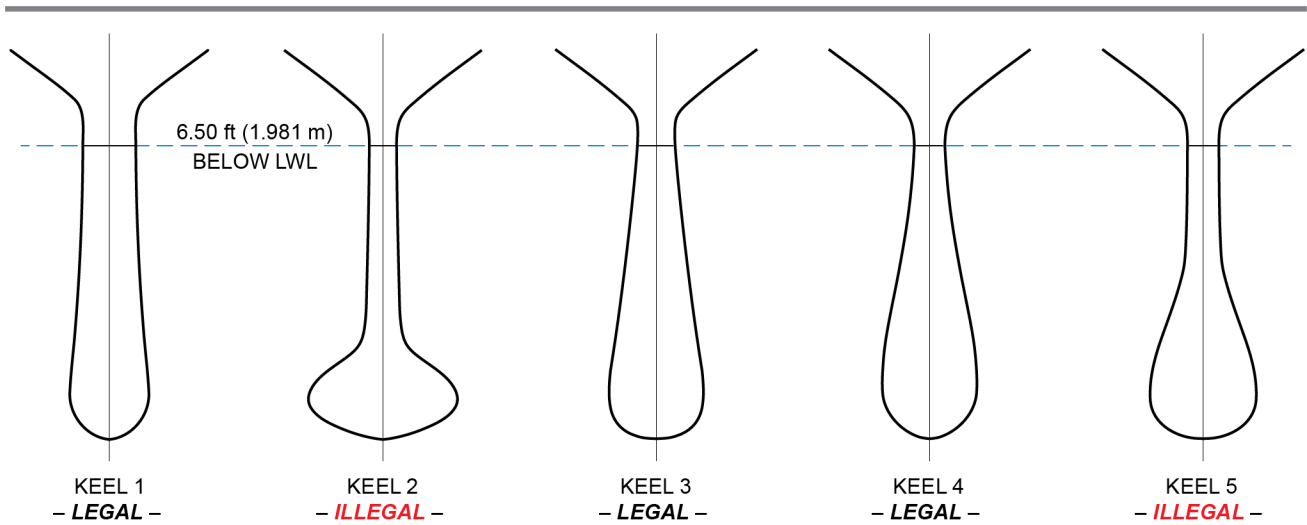

FIGURE 13-3 — LEGAL AND ILLEGAL KEEL TRANSVERSE SECTIONS

Figure 13-3 shows five possible keel transverse sections. Some of these are legal shapes, and some are illegal. These shapes will form the basis for defining a bulb, in terms of a methodology which can be used simply and quickly by either a designer drawing a boat, or a measurer verifying the compliance of a boat.

Keel transverse section 1 is a slightly hollow simple airfoil configuration, as was just encountered in Figure 13-1a and 13-1b. Section 1 is clearly legal. Transverse section 2 is the exact opposite extreme, a shape which is clearly a bulb, and as such is illegal under the New Universal Rule, Class M. The legality of the remaining three shapes is not so easy to determine.

Transverse section 3 is a nearly straight-sided section, but one with a breadth near the tip chord of the keel which is substantially thicker than the keel's root chord. There is, however, nothing bulbous about this transverse section, and it is considered to be an airfoil, not a bulbed airfoil, and hence it is legal.

Even more questionable are transverse sections 4 and 5. With section 4 there is a clearly bulb-like increase in chord thickness nearing the tip, but it isn't a sudden or dramatic change. It is much like section 3 in that the keel simply gets thicker as it nears the tip chord. What differentiates it from section 3 is that the sides are not nearly linear as is the case with section 3, but rather are clearly "bowed" outward to move the center of gravity lower in the keel by narrowing more of the keel below the root chord. This is arguably the "beginning" of a bulb, which it does seem to be, but still it is primarily a plain keel as opposed to a bulb keel. Section 5 goes further, having a sharp change in curvature in the section about 1/2 of the span down the keel section from the reference waterline, the -6.50 ft. waterline (-1.981 m).

The determination of where a bulb actually begins will be a function of this rapid thickening as one moves down the keel span from the reference waterline. In the case of the keel section (section 4) which showed the beginning of a bulb, but still was basically a plain keel section, the minimum radius of curvature of the side of the keel section, in the vertical plane, is about 32% of the class rating. As section 4 seems to exemplify the dividing line between a bulb and non-bulb keel, that radius, 32% of class rating, is taken to be the limit line for a keel. Therefore, if a keel has, as does transverse section 2, a region of concave curvature less than 32% of class rating, taken below the -6.50 ft. (-1.981 m) waterline, then that keel is deemed to be a bulbed keel, and is illegal. If, in the region below the -6.50 ft. waterline, there is no place with a transverse hollow whose radius less than 32% of class rating, then that keel is deemed to be a non-bulb keel, and is deemed to be legal in that particular regard.

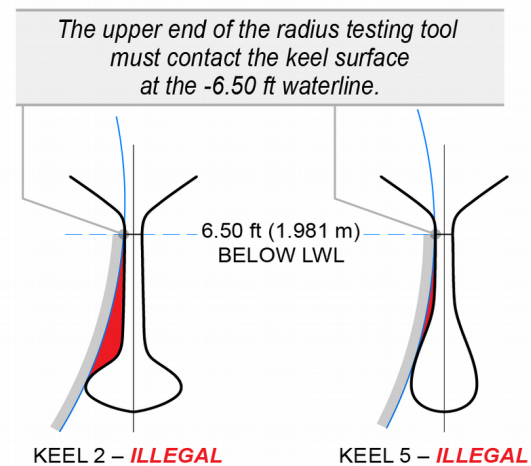
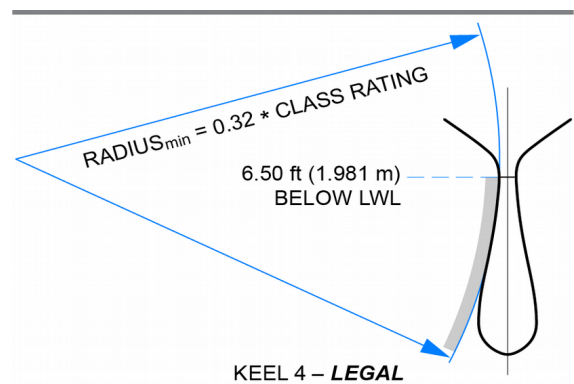

FIGURE 13-4
DETERMINING LEGALITY OF KEELS
WITH GREATER BREADTH NEAR TIP

Figure 13-4 illustrates the regions in which the two illegal keels have transverse section curvature radii which are below the legal minimum, as indicated by the red areas (note that in section 5, the region of curvature with radius less than 32% of class rating is difficult to see in the drawing, but it does render the section 5 shape illegal).

While they have been modified since, the keels in Figure 13-3 were originally drawn with essentially equal cross-sectional area in the region from the -6.50 ft. waterline to the bottom of the keel. Note though that the surface areas would differ greatly, making it unlikely that some would ever be used, but note also that the surface areas of section 3, 4, and 5 are all fairly similar, such that this distinction about bulbs becomes very important, since any of those sections might readily be used.

In addition to questions about bulbs, there arises also the possibility that someone might attempt to use narrow, long winglets to simulate a bulb. Clearly this attempt to circumvent the intention of this Supplement 13 would be illegal, but it might be difficult to define.

The New Universal Rule of Measurement, Class M, defines a winglet as follows:

“winglets are airfoil surfaces mounted to the keel near the bottom of the keel, and projecting outward very approximately perpendicular to the surface of the keel.”

Therefore, to be a winglet, the structure in question must be an airfoil surface. A streamlined raised portion would, therefore, automatically be a bulb since it is not an airfoil surface, and hence not a winglet.

It is also possible that someone might make a very long, very narrow winglet, with an airfoil shape, and at or near the maximum thickness ratio of 15% of chord length. Here some judgment is needed, and that judgment will depend to some extent on the actual length of the winglet, and to some extent on the weight of the winglet.

As a basic norm, a winglet – as the airfoil surface requirement indicates – is a device intended to influence the flow of water over, and aft of, the lower portion of the keel. It may, as a secondary purpose, also house some heavy material which will exert a small influence on the boat's stability. As long as those are the functions that the winglet fulfills, and it fulfills (or attempts to fulfill) the aerodynamic function as well as the ballasting function, then it is probably still a winglet. This is clear in the case of a winglet which is more-or-less rectangular or tapered rectangular in planform, even when it has an area of increased sweep angle where it is attached to the keel (though this area must not extend beyond 6 in (152 mm) from the winglet).

In the case of a delta wing type of winglet, a less rigid application of the principle in the previous paragraph would be called for, but the requirement that the winglet continue to be an airfoil surface, and that it have enough breadth to give a reasonable possibility of it behaving as a winglet, would have to be met.

An even more questionable case is the possible use of a “Concord” style of wing planform as a winglet. In this case, the winglet, like the delta wing winglet, would have to be an airfoil surface, and have enough breadth to have a reasonable chance to behave as a winglet. Additionally, the narrower (forward) part of the winglet would have to be of a size appropriate to that kind of planform, not a gross extension which clearly is primarily to add weight to the keel.

In both the case of the delta wing winglet, and the case of the “Concord” planform winglet, the deciding principles are going to be whether the winglet is clearly an effort to make an efficient winglet which may also add some low ballast, or whether it is clearly an attempt to use a winglet concept primarily as a source of ballast addition. If it seems definitely an attempt primarily to make an efficient winglet, then it is probably legal; if it seems a clear or probable attempt mainly to add ballast, then it is effectively a bulb, and is illegal.

Finally, designers and owners are again reminded of the warning in Appendix 1 of the New Universal Rule of Measurement, that obvious attempts to circumvent the clear intentions of the Rule will be disallowed, notwithstanding their compliance with the letter of the Rule.

SUPPLEMENT 14***Some General Questions about Hull Forms and Appendages***

Following are some questions which could arise about hull forms and appendages:

Question 1: Are twin rudders (one on each side of the boat) permitted?

Answer: No [See Rule Section 3.1.1.1 regarding permissible rudder locations]

Question 2: Are “zero” sections (sections which are very flat across the centerline for some considerable breadth) in the forward part of the boat permitted?

Answer: Yes [See Appendix 1, first paragraph]

Question 3: Are sharp knuckles in the stem profile on the forward overhang permitted (as in the J Class *Ranger*)?

Answer: Yes [See Appendix 1 regarding historical precedent]

Question 4 : Is a “square” stern, such as was used on the 12-Metre *Mariner*, permitted?

Answer: Yes, in principle. However, see Rule Section 3.1.1.1 regarding permissible rudder locations. With regard to the large step entirely below the LWL: while the “square” hull form is permissible, care would have to be taken to be sure the rudder mounting is legal. Section 3.1.1.1 says a rudder may be mounted on a skeg or keel; the word may is permissive, not mandatory, so some other mounting, such as was used on *Mariner*, would per se be legal. However it is also necessary to comply with Rule Section 3.1.1.2, rudder maximum depth. As long as the design complies with all the rudder requirements, the “square” stern configuration would be legal with regard to the below-waterline step.

A second question arises about *Mariner’s* second step, above the waterline. While hollows in the counter profile are permissible, and hollows anywhere in the surface of the hull are permissible (except in the stem profile), there arises a question about measurement of the counter angle. In this case, the counter angle would be taken anywhere along the counter which gave the smallest counter angle.

Finally, it is again pointed out that many hollows are subject to bridging for measurement purposes.

Question 5: Are “reverse” or “forward-sloping” transoms permitted?

Answer: Yes, but see Rule 1.3.6.2 and Supplement 11 for construction requirements for reverse transoms, and for methods of calculating the additional structure weight required by Rule 1.3.6.2.

Question 6: Are “double” transoms, that is transoms which consist of two parts at different angles to the vertical, permitted?

Answer: No. There is no known precedent for such a shape in the history of the M Class or in a related class as defined in Appendix 1. Therefore there should be no more than one transom.

Question 7: Are chines permitted?

Answer: Yes [See Appendix 1, first paragraph]

Question 8: Is a transom which is curved in profile, such as was seen on several 12-Metres, legal?

Answer: the legality of this profile depends on the particulars. As a general statement, if all points on the profile fall within the limits of transom slope [See Rule Section 1.3.6.2], then a curved profile would in general be legal. A specific determination should be made for each individual case, however.

Question 9: Are winglets permitted?

Answer: Yes, subject to all the requirements of Rule Section 3.1.6. Note also that some rules for particular events which are not specific M Class events may not permit boats with winglets to enter.

Question 10: Is it a requirement that the forward portion of the hull be shaped such that the location of the forward end of QBL does not lie further aft than $0.117 * LWL$ aft of the forward end of LWL?

Answer: No. The hull may be narrower than $B/4$ at the distance of $0.117 * LWL$ aft of the forward end of LWL, which would – absent the $0.117 * LWL$ limit – cause the forward end of QBL to be further aft than $0.117 * LWL$ aft of the forward end of LWL, *but the forward end of QBL for measurement and rating purposes (for determination of any QBL penalty) will be taken in that case to a point $0.117 * LWL$ aft of the forward end of LWL, notwithstanding the shape of the hull.* This could create a Quarter Beam penalty.

SUPPLEMENT 15***Some Notes Regarding the Example Boats Used in the Measurement Rule***

The New Universal Rule of Measurement contains demonstration, or example, boats, Hull 66F15c and Hull 66F22a as of Rule version 12.0.1.

It should be noted that these boats are in the rule to provide general concepts only, and to illustrate rule features, to show how a particular measurement is to be taken, and to give a demonstration of some of the concepts in the construction scantlings. These boats are not meant to illustrate what the maximum value of rule parameters would be, nor are they meant to indicate for any particular detail what the boat must look like. It is meant to give a general impression of what a boat designed to this rule is expected to look like.

These example boats may be short of, or even well short of, measurement rule maximums and limits, and should not be scaled or relied on in any design process. They are in the Measurement Rule for illustrative purposes, and in some cases for conceptual purposes, only.

SUPPLEMENT 16***Shallow Hulls with Higher Aspect Ratio Keels – Depth Penalty***

It would be conceivable to design a boat to the New Universal Rule for Class M with a very shallow hull and a higher aspect ratio keel. While at first glance this seems like a very probably successful thing to do, there are a number of serious problems with it, which would immediately present themselves if such a form were actually to be built and were to prove to be fast. These problems include --

- ◆ the underbody of the hull would suddenly be very non-traditional, a situation which the rule strives to limit;
- ◆ an existing fleet of more traditional hulls, that is boats with V-shaped mid-sections, might be instantly obsolete and useless for racing;
- ◆ headroom might be seriously compromised, or at very least a large, ugly deckhouse might be required to maintain the headroom;
- ◆ location of the engine and generator could become a serious problem, cramping the interior.

Some preliminary work on this shallow kind of hull has indicated that they are disastrously slow, at least in some conditions. However, that work is by no means exhaustive, and for all of the above reasons, and possibly other reasons as well, it is deemed desirable to maintain the general V-shaped maximum depth section with its high deadrise. This decision is consistent with the Introduction to the Measurement Rule, which indicates the desire that development under this rule be very seriously limited. Even then, there are a number of variations which could arise, so this Supplement is included to clarify what is permitted without penalty. This is done with the “d” girth difference penalty in the International Rule, but that system penalizes *any* concavity in the 55% LWL section, whereas the intention of the depth limitation in this rule is to prevent shallow hulls, but not to prevent minor hollows in the maximum depth section of a deep hull, which as transverse sections may – as is clarified in Appendix 1 of the Rule – be of any shape.

The depth portion of this rule involves determination of the Hull Depth Offset (HDO), which, if greater than a particular value, results in the penalty P_{depth} . See Rule Section 1.1.2.8.

Figure 16-1 shows 12 different variations of maximum depth sections which might be drawn to this Rule, absent any restriction on depth. Some are quite extreme, and would probably be impractical, while others are very practical, including even some of the more extreme sections.

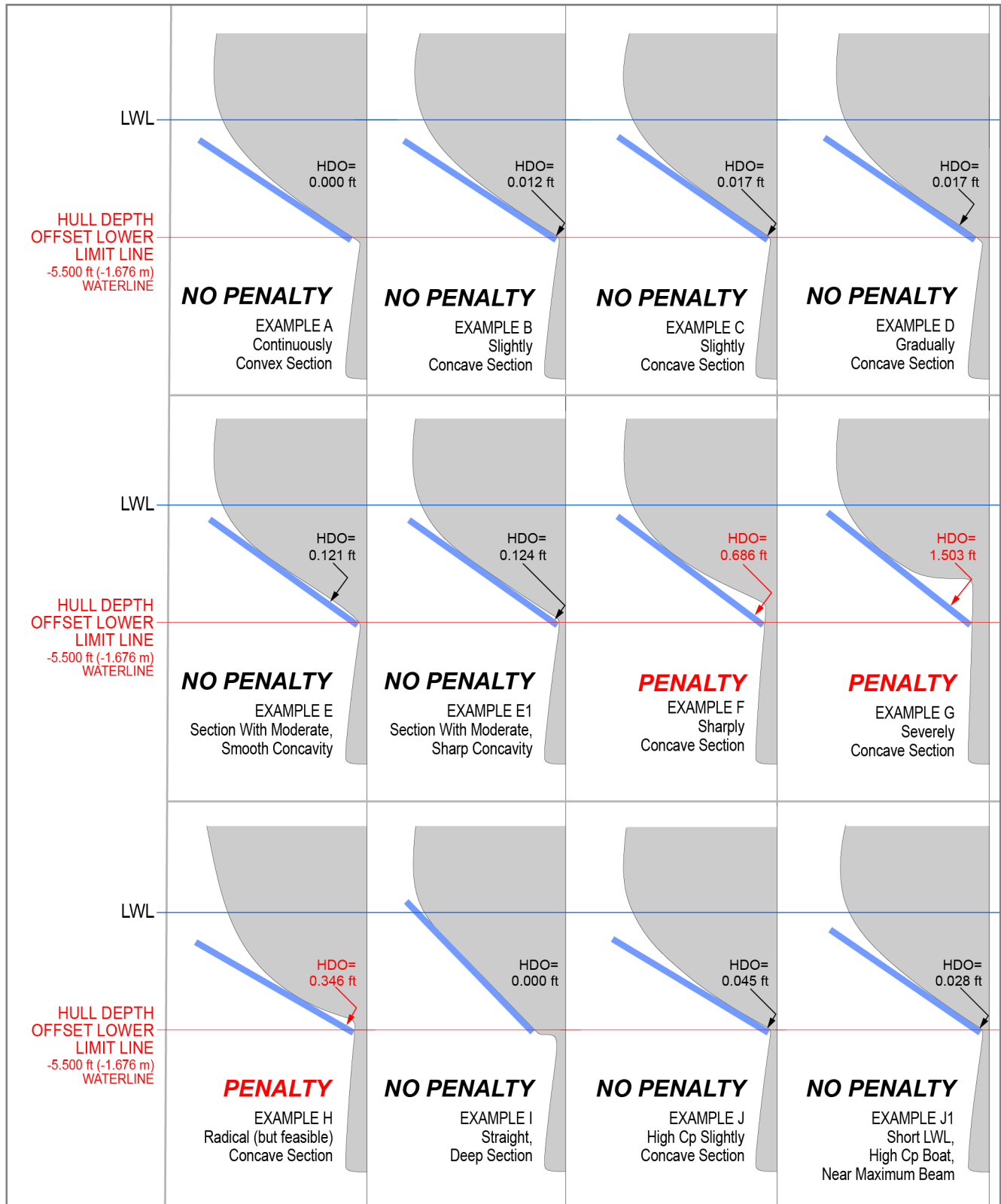

FIGURE 16-1. POTENTIAL MAXIMUM HULL DEPTH SECTIONS

Figure 16 - 1 shows a number of theoretically-possible midsection configurations, several of which have actually been tried in simulation, and several of which are not very realistic due to the problems with total displacement and prismatic coefficient (among other things) which would immediately arise. They are all included here as they are, taken together, illustrative of what is and what is not considered to be an acceptable midsection kind of shape for M Class boats built to the New Universal Rule of Measurement. These possible maximum-depth sections represent a wide variety of boats which could be developed under this measurement rule, and are evaluated here by means of a tangent from the hull cross-section to a point on the hull, fillet or keel (wherever that point lies), 5.50 feet (1.676 m) below the LWL. The perpendicular distance from that tangent to the hull, at whatever point gives the largest measurement, is taken as the Hull Depth Offset, and is used here to evaluate the desirability and hence legality of the sections...

- ◆ Examples A, B and C are very moderate maximum depth sections, of a kind which is envisioned to be the usual kind of shape under this rule. Example Section A has no hollows at all until the final inflection into the keel; Section B has a very slight concavity, and Section C has a slightly greater concavity,
- ◆ Example D has a concavity of the same magnitude as Example C, but the center of – or point of greatest – concavity is well up the underbody of the section, not at the point of final inflection into the keel.
- ◆ Examples E and E1 are sections with greater concavity. Each is still a deep, V-shaped section, but each approaches the task in a different way. These are, on inspection, about the greatest deviation from the shape of Example A as one would be able to call a very similar boat, and from which one could reasonably expect roughly comparable performance. Section E has its point of maximum concavity well up the section, while Section E1 is a similar section with the point of maximum concavity located at the final inflection of the section into the keel. The maximum deviation is, however, virtually identical.
- ◆ Examples F and G are clearly shallower hulls, and are the kinds of shape that the hull depth limitation seeks to avoid.
- ◆ Example H is a very different kind of section, which was derived from a similar section actually used in one simulation. This is not the kind of shape that is desired in boats built to this rule, and is also heavily penalized, though a very slight tendency in the direction of this shape would receive only a much smaller penalty. In that case, though, the performance alteration would probably be slight also, so that the reduction in penalty is appropriate.
- ◆ Examples J and J1 are especially significant, as they are maximum depth sections from possible hulls with a higher prismatic coefficient than the other hulls. Example J is for a boat of the same LWL as the other examples, while Example J1 is the maximum depth section for a significantly shorter LWL boat, which is a configuration where it might make especially good sense to use a higher prismatic coefficient, and also to be fairly close to maximum beam. That is the case for Example J1, which illustrates that the resulting section still fits well within the Hull Depth Offset suggested by the earlier examples.

The question then becomes, “which shapes are consistent with the traditional midsection shape of these kinds of boats, and with the kind of shape which is likely to get the class off to a good traditional start, and then maintain the competitiveness of the boats which were first to be built?”

Any answer to that question will tend to be somewhat arbitrary, but that fact does not prevent a reasonable conclusion from being reached. The answer is clearly a V-shaped maximum-depth section, regardless of whether or not it contains hollows. A quantitative norm is then needed for designers to use in their choices of maximum depth sections, and for measurers to use in determining the penalty for any boat in question which exceeds that maximum.

Figure 16-1 illustrates a straightedge, tangent to the body of the midsection at whatever point along that section the line intersects the section's surface, and run to a point on the hull or keel or keel fillet at a vertical height of 5.50 ft (1.676 m) below LWL. The greatest perpendicular distance from that straightedge to the surface of the hull, taken in the transverse plane, is the Hull Depth Offset (HDO). Figure 16-2, below, illustrates this

measurement. In practice, this Hull Depth Offset should be taken at several transverse sections near the apparent maximum depth of the canoe body of the boat, with the least Hull Depth Offset number from the several transverse sections counting as the actual Hull Depth Offset. This is analogous to the determination of B, where it is also necessary to take several tries to arrive at the maximum dimension for that boat.

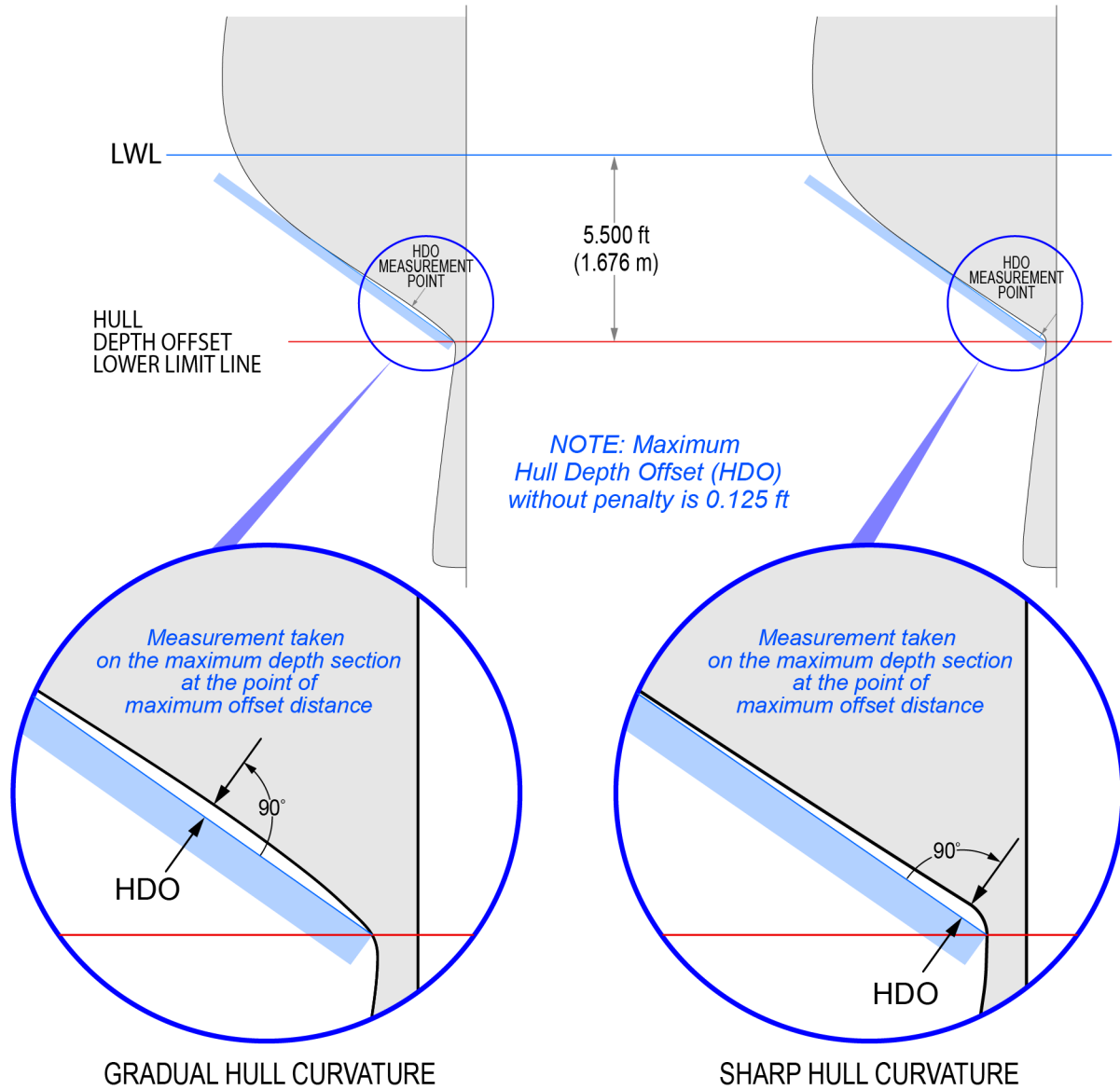

FIGURE 16-2. HULL DEPTH OFFSET MEASUREMENT LOCATIONS

A question could arise about the legality of the use of a strut or bridge, spanning the hull / keel intersection or any other part of the transverse section at the point of measurement of HDO, in order to avoid or greatly reduce the depth penalty, by forcing the measurement of HDO to be taken to the strut, rather than to the hull, fillet or keel. Clearly a “rule-beater”, this is contrary to the warning contained in Rule Appendix 1 about boats which comply with the letter of the rule but are clearly outside the intent of the Rule, and as such will be deemed illegal.

Should any hull form appear to the measurer or the boat's designer to be treated unfairly under this element of the Rule, the matter should be referred immediately to the Rules Committee.

SUPPLEMENT 17

Clarifications About Required Interior Arrangements

Section 6.2 of the New Universal Rule of Measurement for Class M gives a list of major requirements for the interior arrangement of the boats. It is not the intention of the Rule to dictate the interior arrangement of the boats, or to constrain them unnecessarily; however, it is the intention of the rule to ensure that a well-equipped cruising interior, by the standards of the early 21st Century, be fitted in the boats, and that no boat suffer a competitive disadvantage compared to another boat because that first boat is equipped with a good cruising interior.

Recognizing that all competitive designers, including those involved in the development of these rules, will by their nature try to gain advantage by minimizing non-structural weights, this Supplement is added to try to put a boundary around what is permitted in an effort to save / centralize / lower weights in the interior non-structural components, so that confusion and discord are, to the greatest extent reasonably possible, avoided.

While it is not the intention of this rule to specify every piece of equipment in the interior of the boat, it is intended to make it clear what the general expectations are, so that there is no uncertainty on this point.

These concepts are included in the Supplement, rather than in the Measurement Rule, as there is no specific hard and fast requirement about the individual items, but rather simply the understanding that high quality, off-the-shelf equipment shall be installed on board, which provides the functions indicated below.

Expectations With Respect to Interior Equipment

Water Systems : It is expected that the boats built to this rule will be capable of a 4 day cruise in coastal waters with a minimum of 8 persons on board. This will require the following capabilities in some form:

- a. ability to generate sufficient fresh water for cooking, personal hygiene, drinking, and any other routine needs, as it is neither desirable nor practical to be able to store this quantity of fresh water on the boat;
- b. water heating capability sufficient for a boat of this size to have a reasonable quantity of hot water delivered at a reasonable rate;
- c. facilities for personal hygiene, taken in this case to be sufficient room in the heads to facilitate routine cleanliness, and also sufficient facilities to permit showering or bathing in some acceptable form. These facilities may be included in, or separate from, the heads required by the Rule, but in any case shall be fully functional when the boat is at rest upright;
- d. appropriate water removal and storage capabilities (including ability to store and remove both gray and black water) in sufficient quantities to permit the boat to function fully overnight in areas where pump-outs are not permitted, until the boat can go the next day sufficiently far offshore to permit legal pumping, or can go to a pump-out station;
- e. pumping system able to provide hot and cold water to the galley, each head, and shower facilities, though the capacity of the system may be limited by a reasonable rate of fresh water production.

Environmental Systems: Sufficient heating and air conditioning systems shall be provided to permit the boat to have a comfortable interior over a reasonable range of conditions that might be found in common cruising grounds. For guidance, but not as a rigid requirement, it is assumed that the boat can deal properly with external temperatures from 50 degrees F to 85 degrees F (10 degrees C to 30 degrees C).

Each area of the boat that is routinely inhabited, that is, the owner's cabin, each guest cabin, crew quarters, and common eating and galley area, should have a controllable heating/air conditioning system, which may be a standalone system, or a separately-controllable branch of a central system.

Location of Engine with Respect to Owner's Cabin

Section 8.1.2 of the New Universal Rule Class M states: “The engine shall not be mounted in, or immediately adjacent to, the owner's cabin.” A question has arisen as to what “...immediately adjacent to...” means.

The purpose of Section 8.1.2 is to prevent engine noise and vibration from being located directly in, or so close to, the owner's cabin that the cabin is not a pleasant place to be when the boat is under way, under power. It is also intended to avoid the necessity to use excessive sound deadening methods to avoid that disturbance. The rule should be applied in that manner.

Specifically, no engine should be actually in the owner's cabin, nor should it share a “wall” or bulkhead of any kind with the owner's cabin. Where the question can arise is the situation where there is a passageway leading to the owner's cabin, and the engine is adjacent to that passageway. For this purpose, the owner's cabin is taken to be the main body of area in which the owner might actually sit or sleep, and would include a head and/or shower if those are essentially part of the owner's cabin. A passageway leading to the owner's cabin would not be considered part of the owner's cabin for this purpose, so that if an engine shares a “wall” with a passageway leading to the owner's cabin, but not a “wall” forming part of the main body of the owner's cabin, that engine location would be acceptable, regardless of whether there was a physical door separating the passageway from the main body of the owner's cabin or not.

Specific Design Guidance on Interior Arrangements & Weights

The Rules Committee's working team considered 3 potential interior arrangements with the goal of finding some characteristics which could guide other designers – and future work by the working team's designers – in determining what was an insufficient, a sufficient, and an over-done interior. The goal wasn't to pin down specific values for parameters, but rather a fairly broad range of values which would still allow great freedom in interior arrangement design, but at the same time prevent great differences in performance from occurring as a result of greatly different weights or weight distribution from one interior arrangement design to another.

The parameters chosen were:

- ◆ number of enclosed private spaces
- ◆ linear length of “walls” (non-structural transverse or longitudinal bulkheads) dividing the private spaces taken at deck level including doors
- ◆ total planform area of enclosed private spaces taken at deck level

Additionally, the total weight of the structure and equipment (less “heavy items”) was considered from one of the designs. The “heavy” items were deemed necessary for all designs, and so were omitted from the total for more variable items. Heavy items omitted were:

- ◆ engine
- ◆ generators
- ◆ batteries
- ◆ refrigerators / freezers
- ◆ ovens / stoves
- ◆ inverters, chargers, etc.
- ◆ cabling, plumbing, etc.
- ◆ pumps, hydraulic lines, etc.
- ◆ tanks, sumps, and any other fluid retention systems.

It would be preferable to use surface area of “walls”, as that is more exactly related to the actual weight, but this is tedious and impractical to do again and again during the design stage, so the linear feet of the “walls” is used instead, on the assumption that it would give an adequate approximation.

The results of this analysis are:

Category	Design “A”	Design “B”	Design “C”
Number of enclosed private spaces	10	10	9
Total linear feet of separating “walls”	114	124	112
Total planform area of enclosed spaces	433 ft ²	422 ft ²	450 ft ²
Enclosed area as % of total usable area	81%	79%	84%

In each design, the area used for accommodation began at Frame 12, and continued aft to approximately Frame 43. While there is no specific requirement to use this full area for accommodation, it is assumed that any interior meeting the intent of this rule would run approximately that length, as it is difficult to fit a good interior into this size of boat at all.

Enclosed private spaces included lockers (other than sail lockers) if the locker was entirely contained within the enclosed area. It was excluded if it was not totally enclosed in that area. Companionways, navigation stations, ladder and stairways, passageways, and sail lockers were excluded from “enclosed areas”, except that if a passageway was *totally* contained in an “enclosed area”, such that it was a part of the enclosed area, (for example an area of transit within a private or enclosed space) then that passageway was included in the “enclosed area”.

All 3 of these proposed arrangement plans were for the same hull, making a reasonable comparison as a portion of the total area available possible. The total deck area of that portion of the boat which was usable was approximately 535 ft². This is a little less than the actual deck area of that hull from Frame 12 to Frame 43, as a part of that area was occupied by a cockpit, which was not included in the “usable” measurement.

Finally, it is worth noting that the total weight of the non-structural transverse and longitudinal bulkheads (“walls”) in Design B was 877 lbs. This should serve as yet another guideline for what is expected in the boat’s interior.

Guidance on Quantity and Nature of Berths

Rule Section 6.2.1.1 is meant to require a minimum number of “quality” berths for pleasant cruising, not to restrict the number of berths which a boat can have. If it is desired to have berths in addition to those required by Rule Section 6.2.1.1 the additional berths may be of any form, including pipe berths.